

Index

089 3-speed Automatic

ATF pump

- assembly 38.20

Direct/reverse gear clutch

- identification 38.13
- installing 38.11

First/reverse gear clutch

- clutch, checking 38.11
- piston, installing 38.10

Forward clutch

- assembly 38.21
- assembly, checking 38.22
- clutch drum 38.22
- end play 38.22
- installing 38.11

Governor

- identifying 38.5
- removing/installing 38.5

One way clutch

- assembly 38.18
- installing 38.12
- removing 38.10

Pump shaft

- length 38.3

Reverse planetary ring gear

- assembly 38.17
- installing 38.13

Second gear brake band

- adjusting 38.13
- checking 38.12

Second gear brake band piston

- assembly 38.17
- cover 38.16
- installing 38.11
- push rod length 38.16
- removing 38.10
- seals 38.16

Transmission

- assembling/disassembling 38.9

Transmission/final drive

- assembly 38.2
- end play, adjusting 38.6
- separating 38.3

Transmission housing studs

- installing 38.4

Turbine shaft

- length 38.3
- seals, checking 38.3
- seals, removing/installing 38.4

Direct/reverse clutch

- assembly 38.23
- checking 38.26
- clutch drum 38.24
- end play 38.24

Parking lock

- assembly 38.33

Valve body

- assembly 38.26, 38.28, 38.31
- disassembling/assembling 38.30
- identifying 38.29
- installing 38.27
- spring table 38.32

Automatic Transmission – Case, Gears, Shaft

Note

Final drive transmission oil seal is installed in the final drive, but sealing lip fits a shoulder on the governor drive gear in transmission.

If only the oil seals are to be replaced, the transmission and final drive must not be tilted when separating to prevent leakage and mixing.

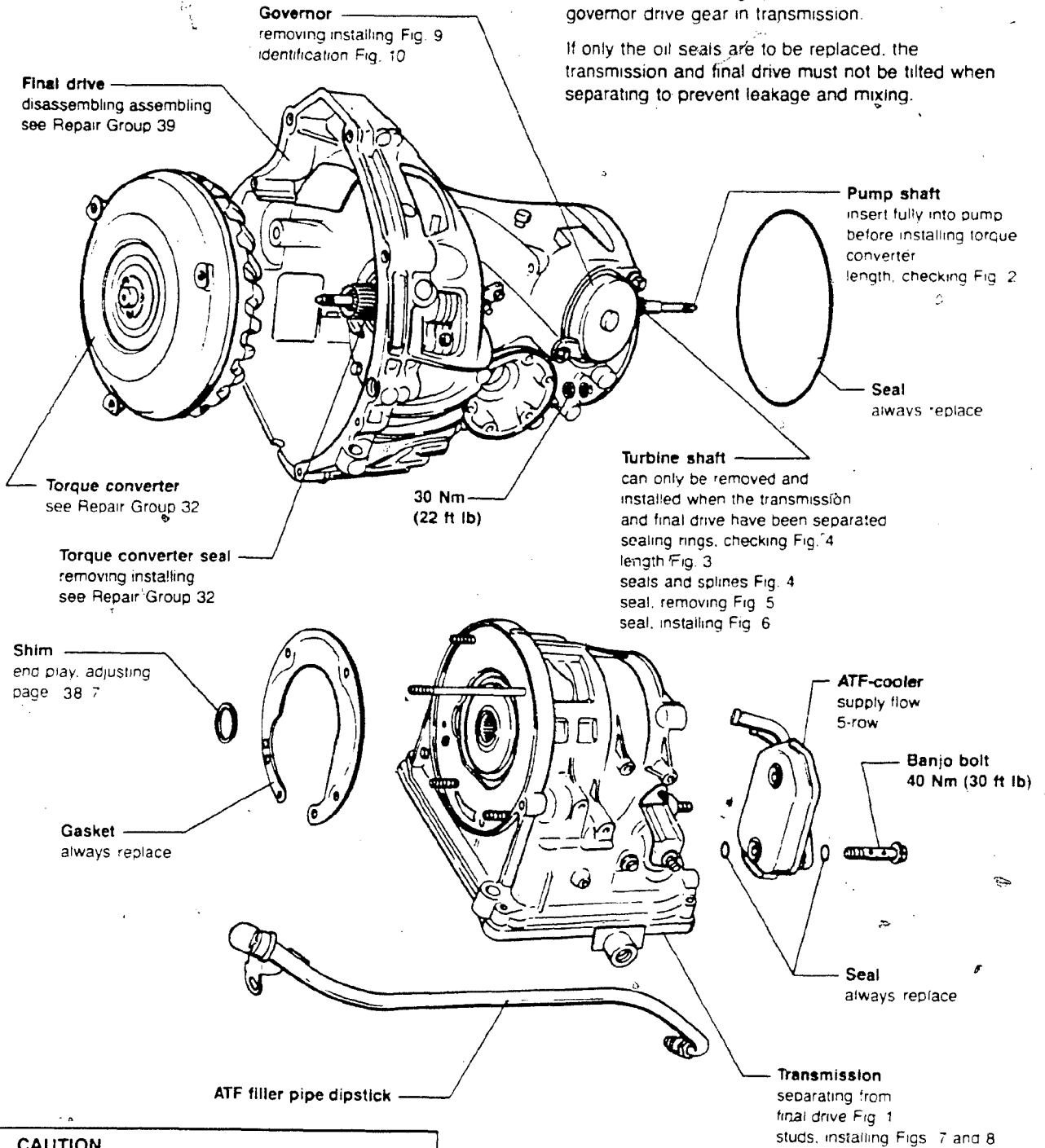

CAUTION

When replacing the final drive or transmission, end play must be checked and adjusted if necessary.

37-665

D-2

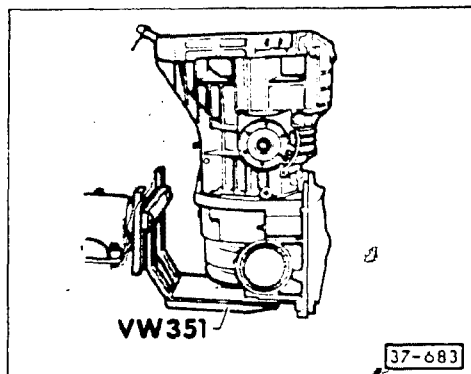

► Fig. 1 Transmission/Final drive, separating

- drain ATF
- drain oil from final drive.
- remove ATF cooler
- mount to repair stand as shown
- remove final drive

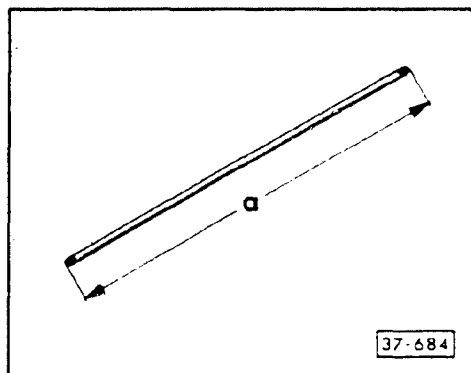

► Fig. 2 Pump shaft, length

- a = 479.6 mm (18.882 in)

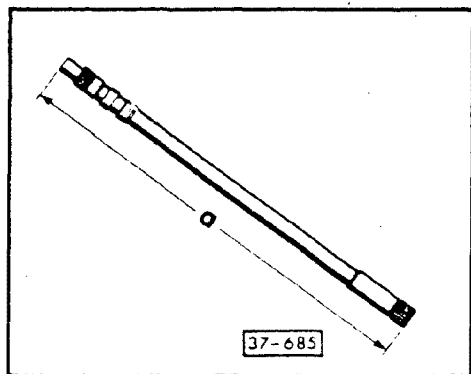

► Fig. 3 Turbine shaft, length

- a = 390.2 mm (15.36 in.)
- turbine shafts are available in various lengths; measure before installing

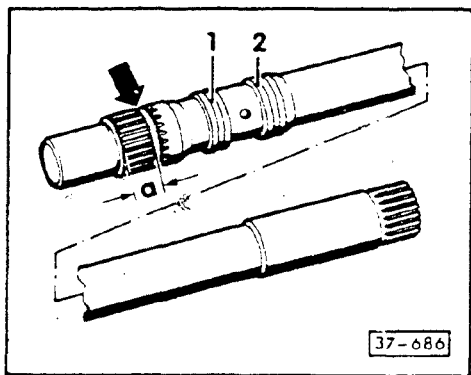

► Fig. 4 Turbine shaft seals and splines, checking

- length of splines a in forward clutch is limited by a circlip (arrow)
- check rings 1 and 2 for wear and correct installation

CAUTION

Never install shaft without circlip.

CONTINUED IN THE
BEGINNING OF NEXT ROW

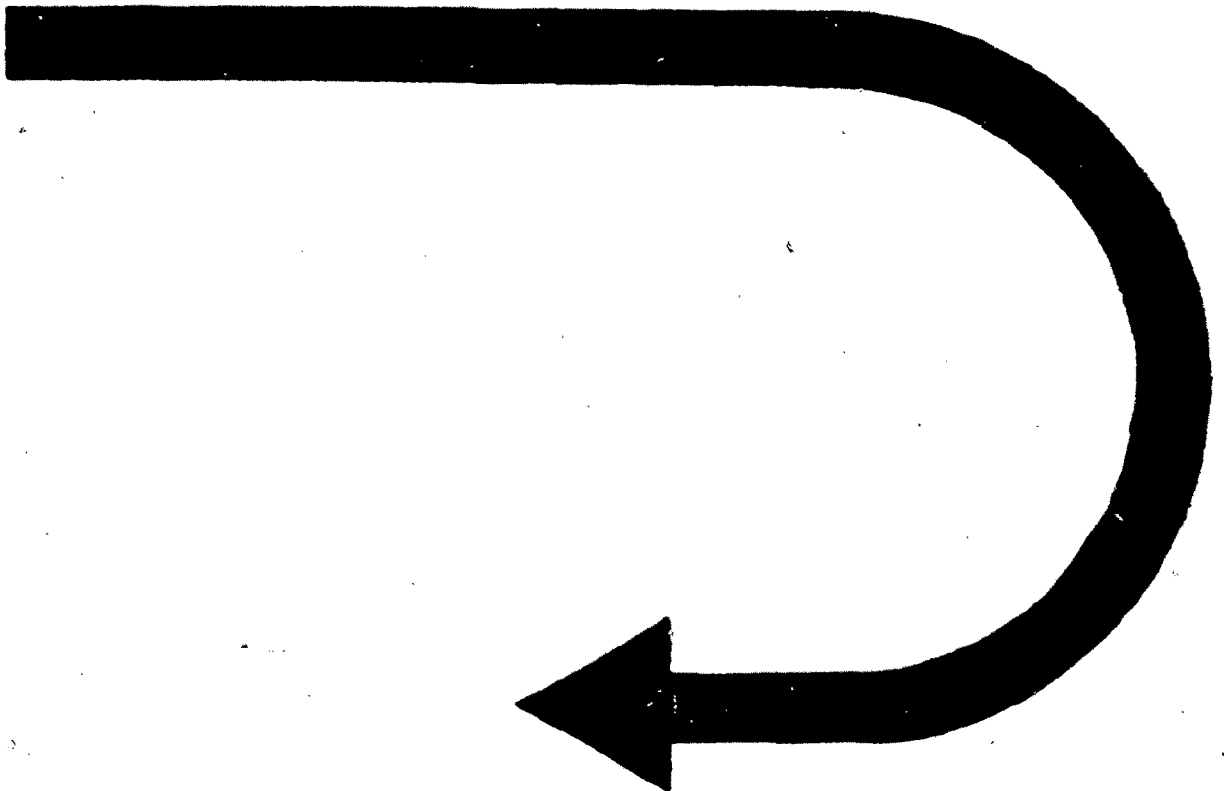

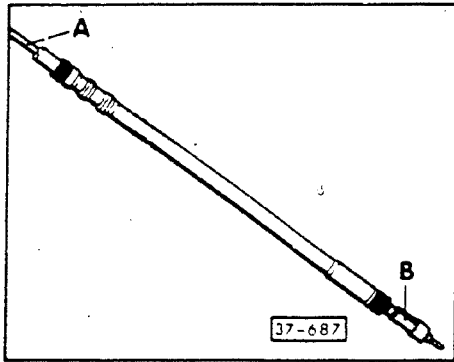

► Fig. 5 Turbine shaft seal, removing

- remove seal with suitable puller
 - A = round bar or old pump shaft
 - B = US 1010 or Kukko 21/1

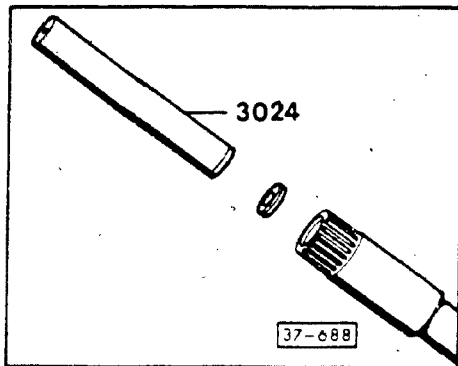

► Fig. 6 Turbine shaft seal, installing

- install seal with open end to outside
- drive seal in until seated

Note

A turbine shaft with a seal can only be used with a pump shaft with tapered splines.

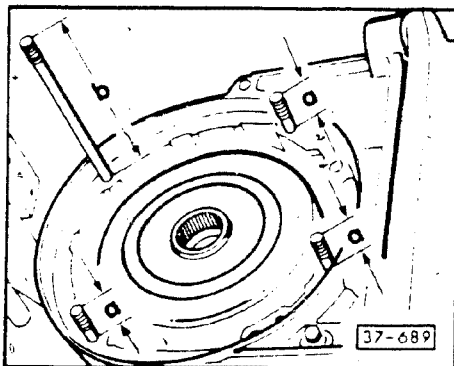

► Fig. 7 Transmission housing front studs, installing

- a = 31.5 mm (1-1/4 in)
- b = 138.0 mm (5-7/16 in)

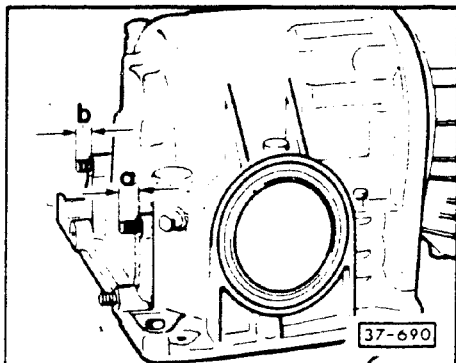

► Fig. 8 Transmission housing rear studs, installing

- a = 18 mm (23/32 in)
- b = 18 mm (23/32 in)

Note

If removed, install studs to the specified length.

Automatic Transmission – Case, Gears, Shaft

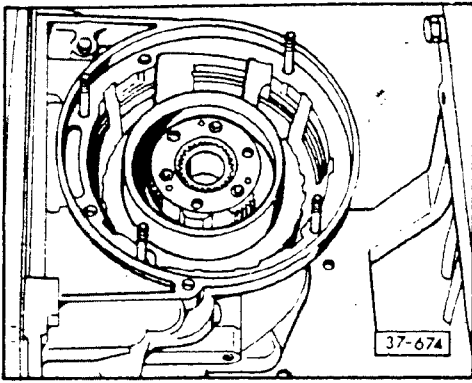

► Fig. 9 Governor, removing/installing

- 1 — governor
- 2 — seal
 - always replace
- 3 — cover
- 4 — bolt
- 5 — spring washer

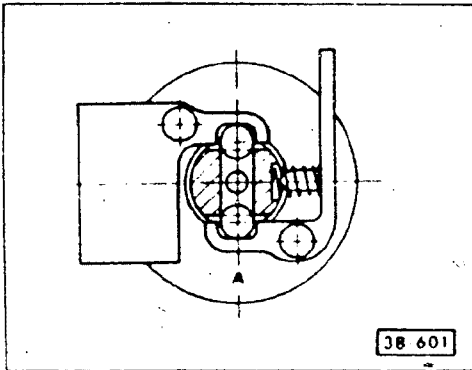

► Fig. 10 Governor, identification

- code letter is stamped on governor head

Transmission application	Governor code letter
all with gasoline engine	A

Transmission/Final drive end play, adjusting

Note

End play y between transmission and final drive must be adjusted to limit reverse planetary ring gear end play.

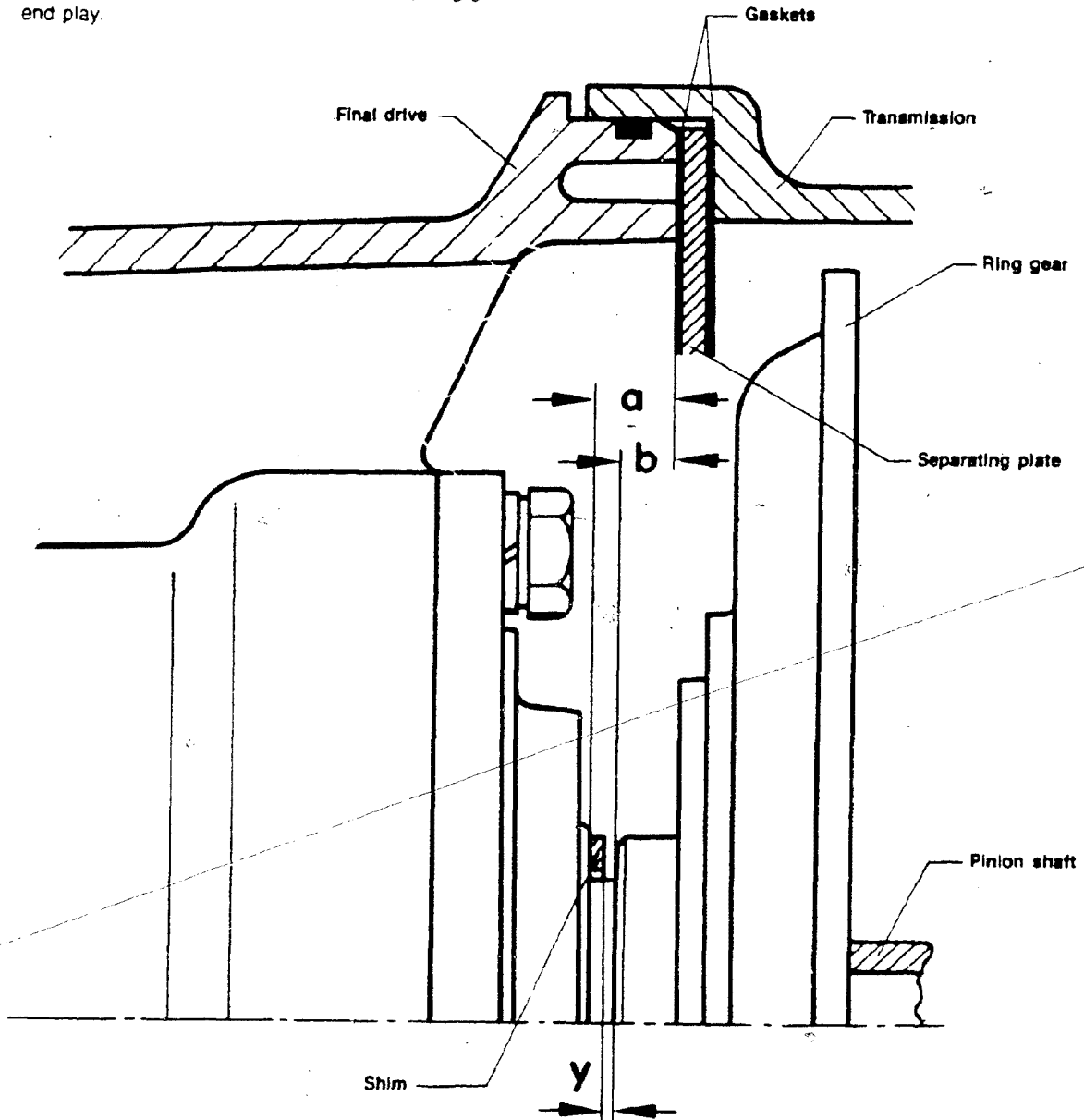

Measuring points

- **a - Final drive:** housing joint surface to oil seal sleeve
- **b - Transmission:** shoulder for shim to separating plate gasket

37-691

D-6

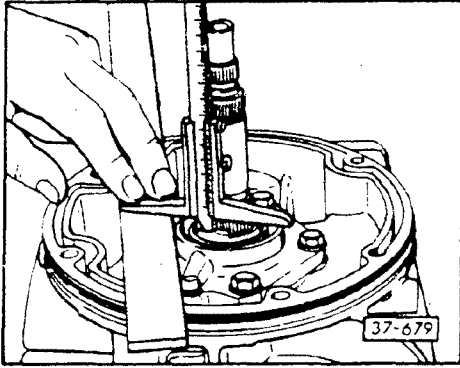

Dimension “a,” measuring

- measure from straight edge to oil seal sleeve

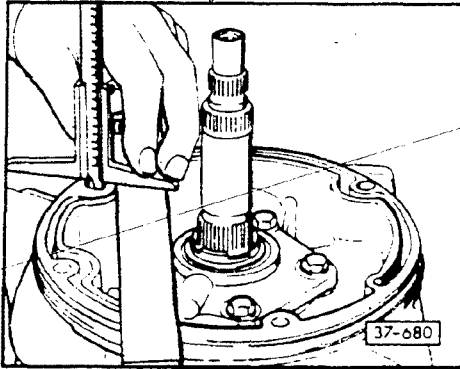

- measure from straight edge to final drive joint surface

Example

straight edge to oil seal sleeve	18.7 mm
straight edge to joint surface	– 8.0 mm
dimension a	= 10.7 mm

Dimension “b,” measuring

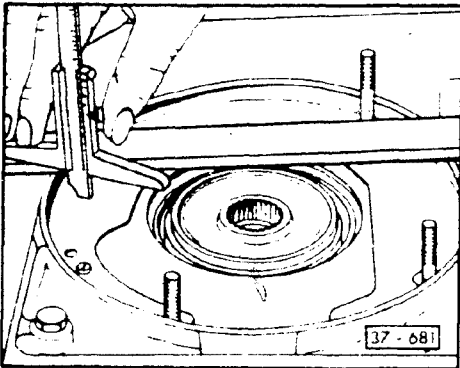

- measure from straight edge on housing to gasket on plate

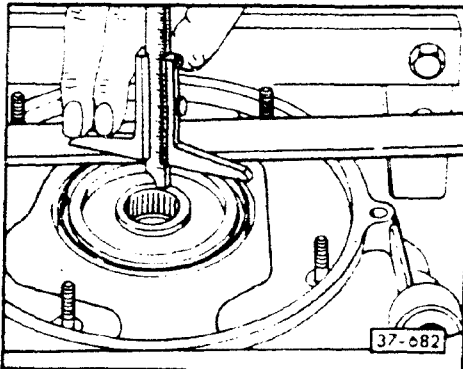

- measure from straight edge to shoulder for shim

Example

straight edge to gasket	19.2 mm
straight edge to shoulder	– 10.0 mm
dimension b	= 9.2 mm

Shim thickness, determining

- subtract **b** from **a** to get **x** (shim thickness)

Example

$$\begin{array}{r}
 \text{dimension a} \qquad \qquad \qquad 10.7 \text{ mm} \\
 \text{dimension b} \qquad \qquad \qquad - 9.2 \text{ mm} \\
 \hline
 \text{dimension x} \qquad \qquad \qquad = 1.5 \text{ mm}
 \end{array}$$

Dimension x mm	Shim mm
0.23 - 0.84	no shim
0.85 - 1.24	1 x 0.4
1.25 - 1.64	2 x 0.4
1.65 - 2.04	1 x 1.2
2.05 - 2.44	1 x 0.4
	1 x 1.1
2.45 - 2.84	2 x 0.4
	1 x 1.2
2.85 - 3.24	2 x 1.2
3.25 - 3.64	1 x 0.4
	2 x 1.2
3.65 - 3.88	2 x 0.4
	2 x 1.2

- select shim from table
- two shim thicknesses are available
 - 0.4 mm — Part No. **010 323 345 A**
 - 1.2 mm — Part No. **010 323 346 A**

CAUTION

Part numbers are for reference only.
Always consult your Parts Department
for latest information.

**This page
intentionally
left blank**

Automatic Transmission – Case, Gears, Shaft

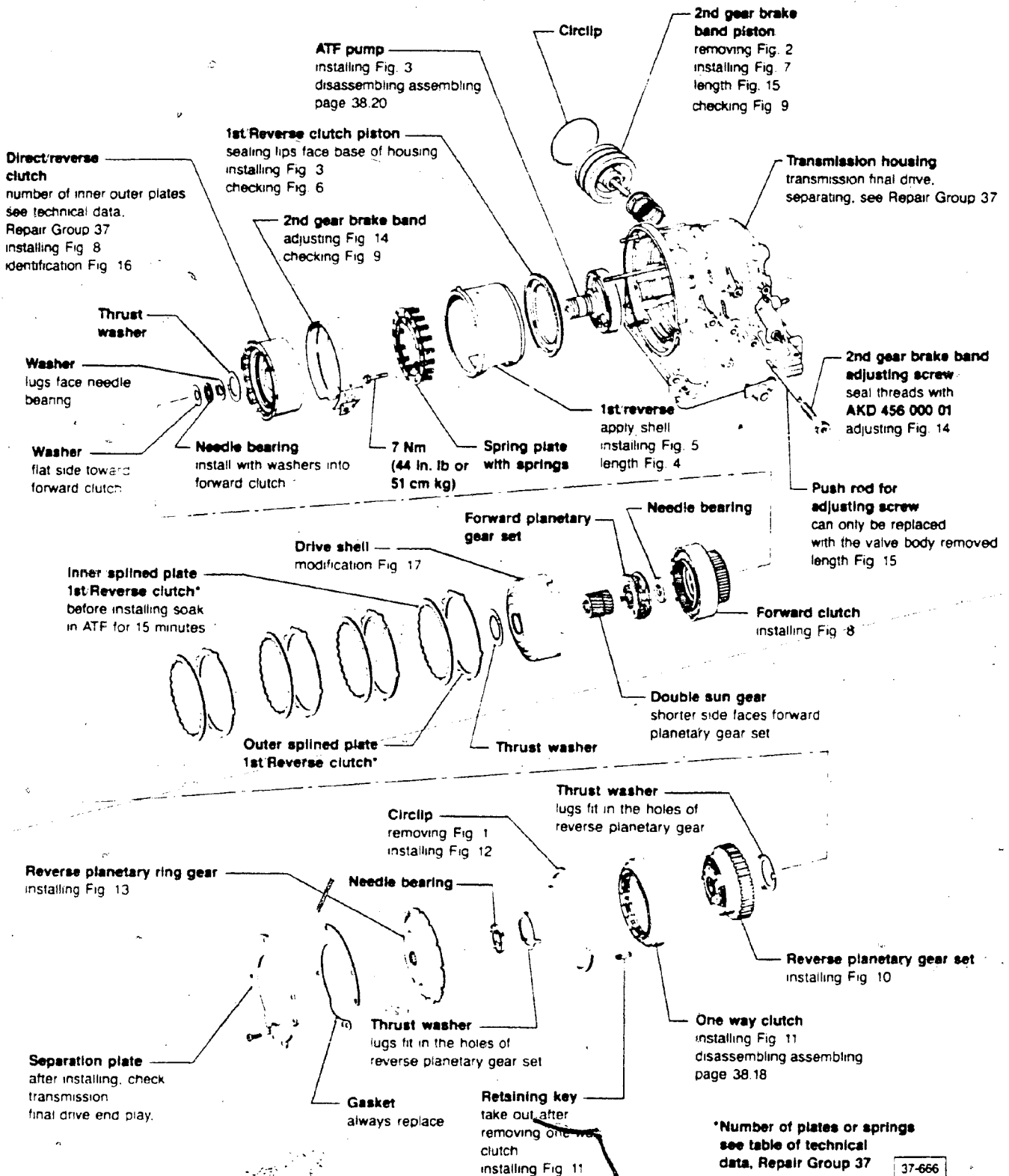

37-666

Automatic Transmission – Case, Gears, Shaft

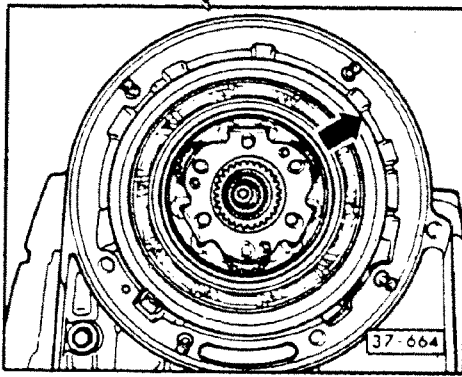

► Fig. 1 Circlip/one-way clutch, removing

- remove circlip from groove (**arrow**)
- pull out clutch

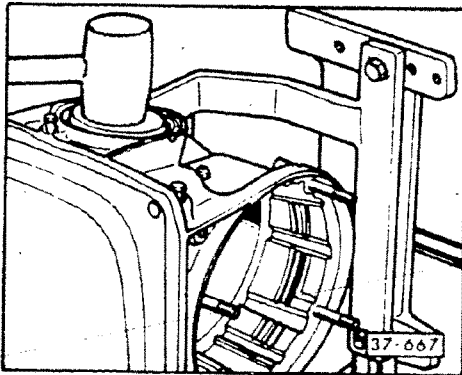

► Fig. 2 2nd gear brake band piston, removing

- take out retaining ring and remove piston by tapping lightly on cover with a rubber hammer

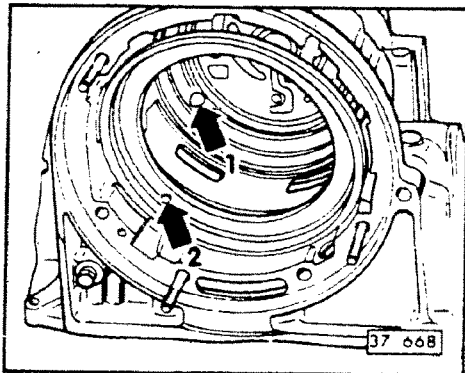

► Fig. 3 1st/reverse clutch piston, installing

- lubricate piston with ATF
- push piston onto ATF pump and fit ATF pump into the transmission housing with the thin rib facing upwards
- align the piston ball valve (**arrow 2**) with the hole in transmission housing (**arrow 1**)

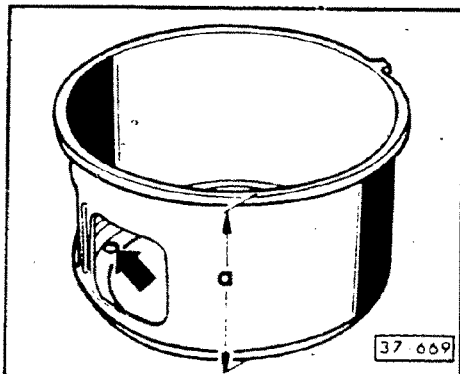

► Fig. 4 Apply shell, measuring

- dimension a is based on the number of inner outer splined plates
 - a = 100.5 mm (3.957 in) for 3 inner 3 outer plates
 - b = 97.00 mm (3.819 in) for 4 inner 4 outer plates
- the hole (**arrow**) must align with the piston ball valve.

Automatic Transmission – Case, Gears, Shaft

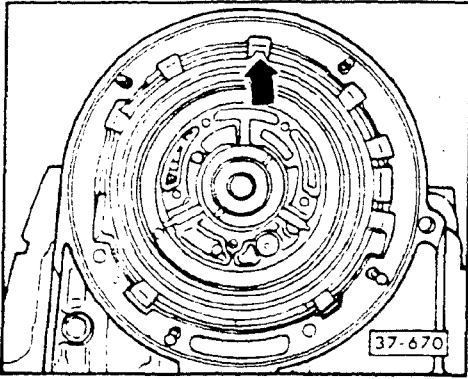

► Fig. 5 Apply shell, installing

- insert lug (arrow) in the groove shown

Note

See technical data in Repair Group 37 for number of inner/outer splined plates.

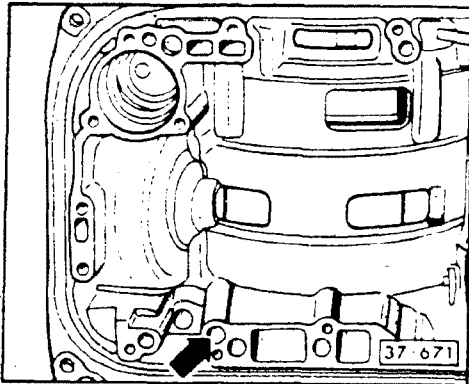

► Fig. 6 1st/reverse gear clutch, checking

- apply low air pressure to port (arrow);
 - piston must compress springs
 - piston must return to original position when air pressure is released

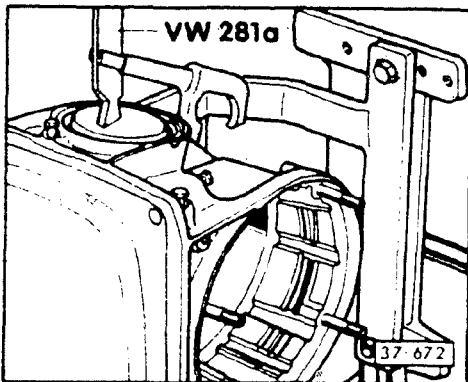

► Fig. 7 2nd gear brake band piston, installing

- press piston down and install circlip
- install 2nd gear brake band

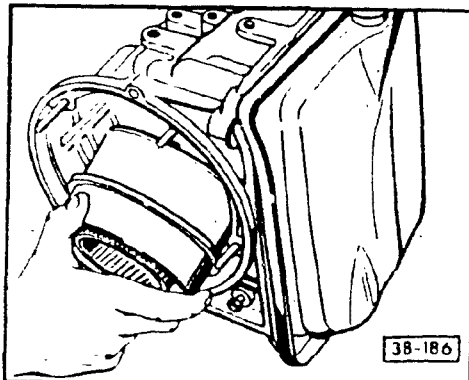

► Fig. 8 Direct/reverse and forward clutches, installing

Note

Assemble direct/reverse and forward clutches before installing into transmission case.

- tilt transmission housing downward and slide clutches onto neck of pump
- tilt transmission housing upward and check needle bearing for fit on oil pump neck

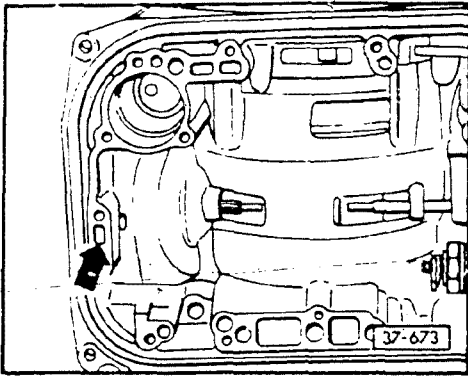

► Fig. 9 2nd gear brake band, checking

- apply low air pressure to port (**arrow**)
- brake band must apply
- brake band must return to original position when air pressure is released

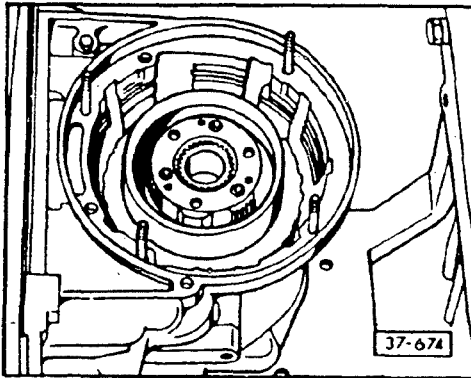

► Fig. 10 Reverse planetary gear set, installing

- install planetary gear set
- insert splined plates

Note

Soak plates in ATF for 15 minutes before installing.

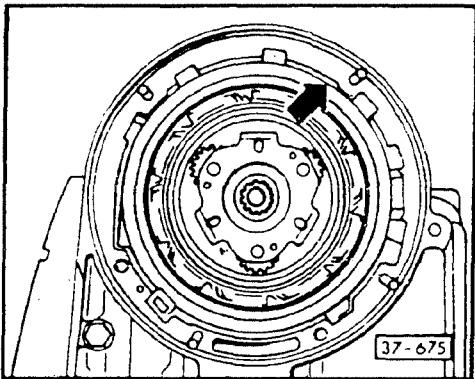

► Fig. 11 One-way clutch, installing

- install pre-assembled one-way clutch and retaining key
- parts have been assembled properly if the groove for circlip is exposed (**arrow**)
- it must **not** be possible to turn the planetary gear set counterclockwise

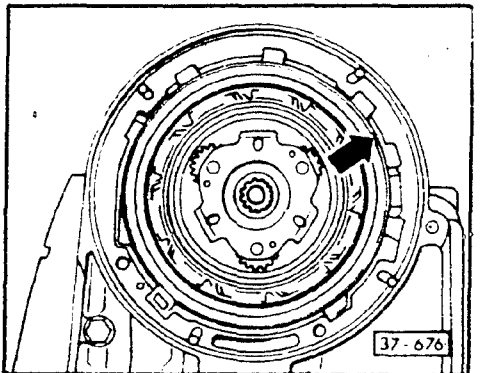

► Fig. 12 Circlip, installing

- circlip opening (**arrow**) must be opposite the retaining key

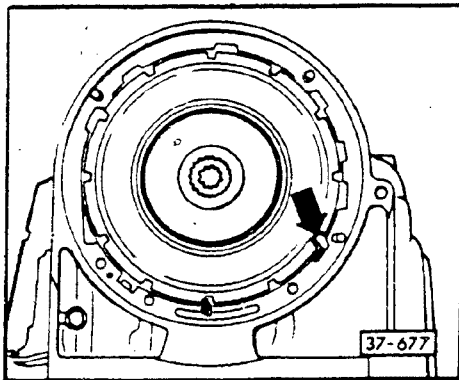

► Fig. 13 Reverse planetary ring gear, installing

- planetary gear notches must be centered with parking lock pawl (arrow)

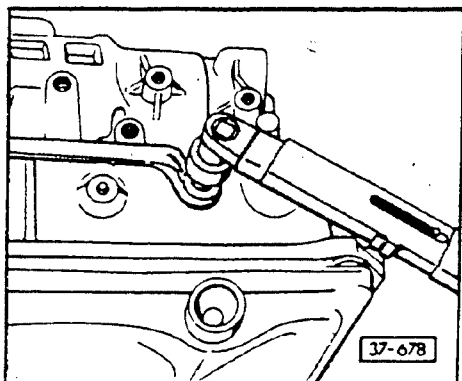

► Fig. 14 2nd gear brake band, adjusting

Note

Coat adjusting screw threads with sealant AKD 450 000 01.

- with locknut loosened, tighten adjusting screw to 10 Nm (7 ft lb)
- loosen, then retighten to 5 Nm (44 in. lb or 51 cm kg)
- loosen from this position, exactly:
 - 2-1/2 turns
 - see Technical Data in Repair Group 37
- tighten locknut

CAUTION

Transmission must be horizontal when adjusting brake band; otherwise band may jam.

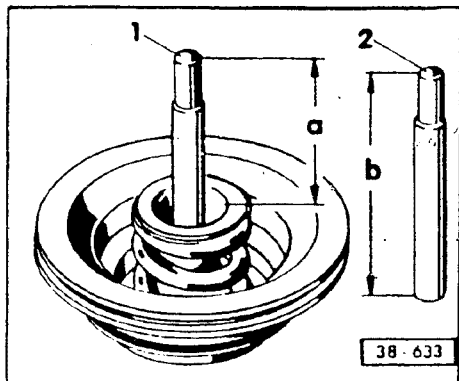

► Fig. 15 Piston/push rod, length

- 1 — 2nd gear brake piston push rod
- 2 — push rod for adjusting screw

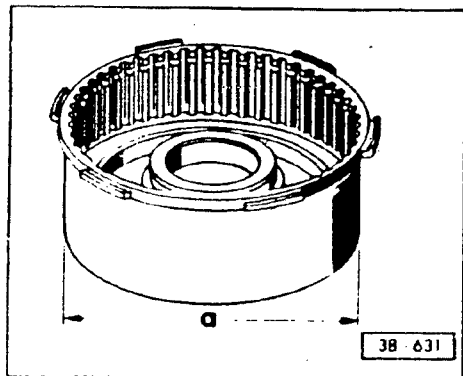

► Fig. 16 Direct/Reverse clutch, identification

D & R Clutch	dimension a (mm)	dimension b (mm)
134 mm diameter	50	92.5
140 mm diameter	52.4	82.5

	dimension a
D & R clutch	134 mm
Larger D & R clutch	140 mm

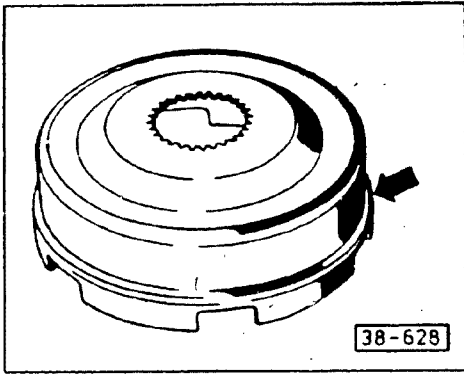

► Fig. 17 Drive shell, modification

- drive shell is wider to fit larger D & R clutch
- drive shell is identified by shoulder (arrow)

Note

Larger drive shell can only be used with larger (140 mm) direct/reverse clutch.

Automatic Transmission – Case, Gears, Shaft

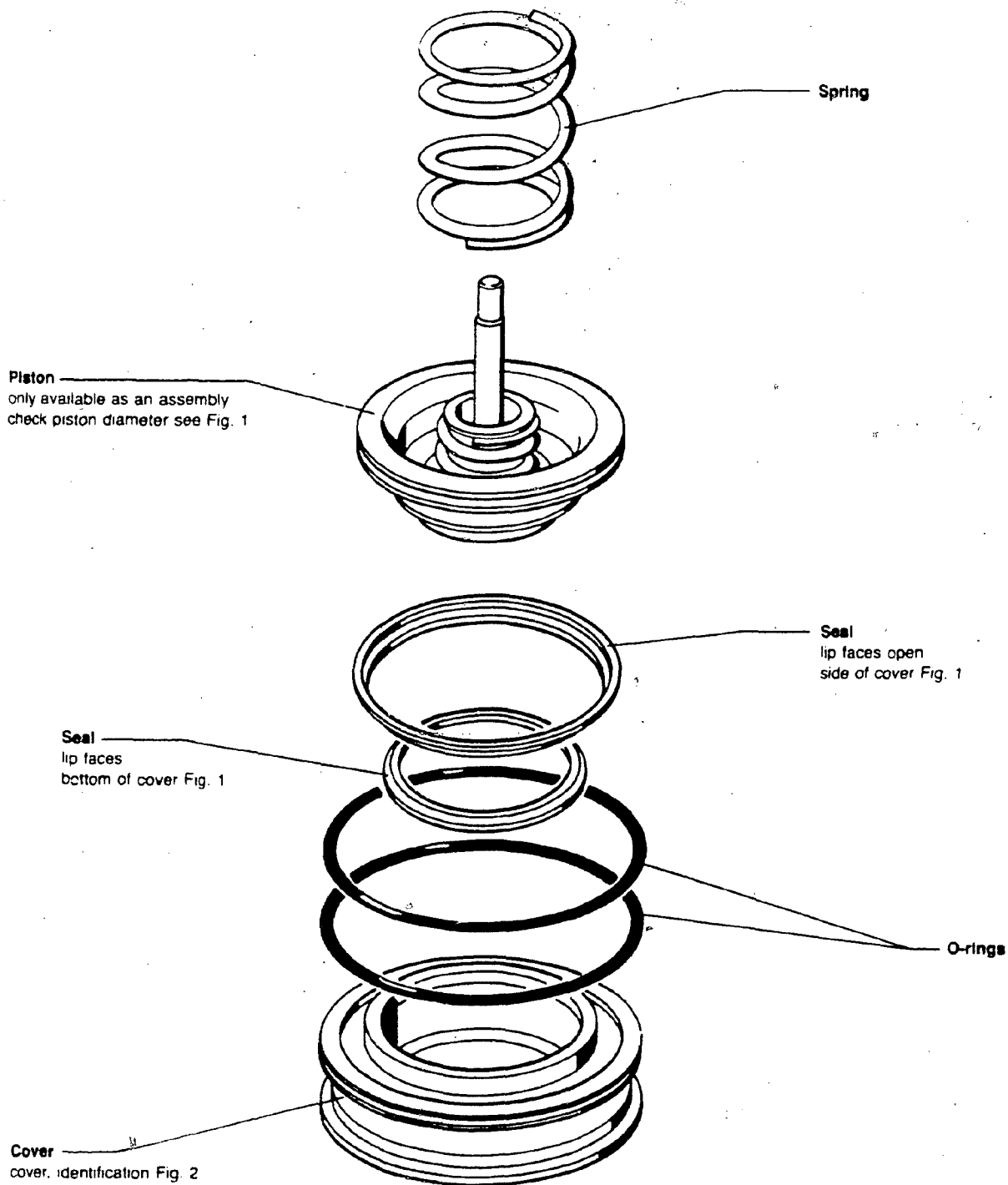

38-677

D-16

089

2nd gear brake band piston

38.15

Automatic Transmission – Case, Gears, Shaft

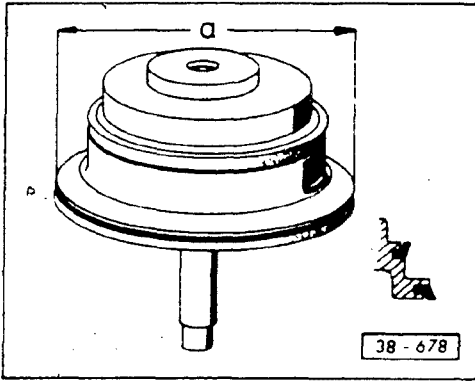

► Fig. 1 Piston and piston seals, positioning

- a = 96.5mm (3.800 in)

Note

The piston, pressure plate, washer, spring and push rod are rivetted and must be replaced as an assembly.

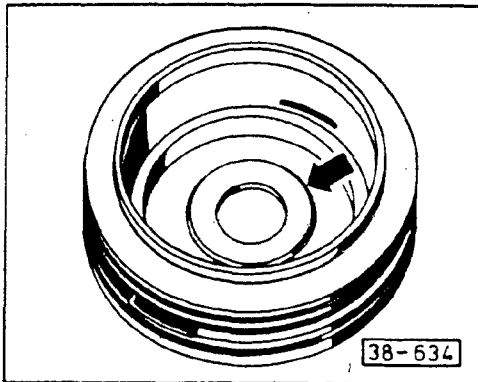

► Fig. 2 2nd gear brake band piston cover, identification

- recess in cover (arrow) provides clearance for rivetted piston assembly

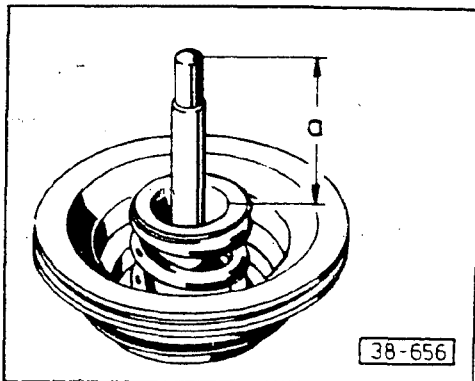

► Fig. 3 Piston/push rod, length

	Dimension a
134 mm diameter D & R clutch	50 mm
140 mm diameter D & R clutch	40 mm

Automatic Transmission – Case, Gears, Shaft

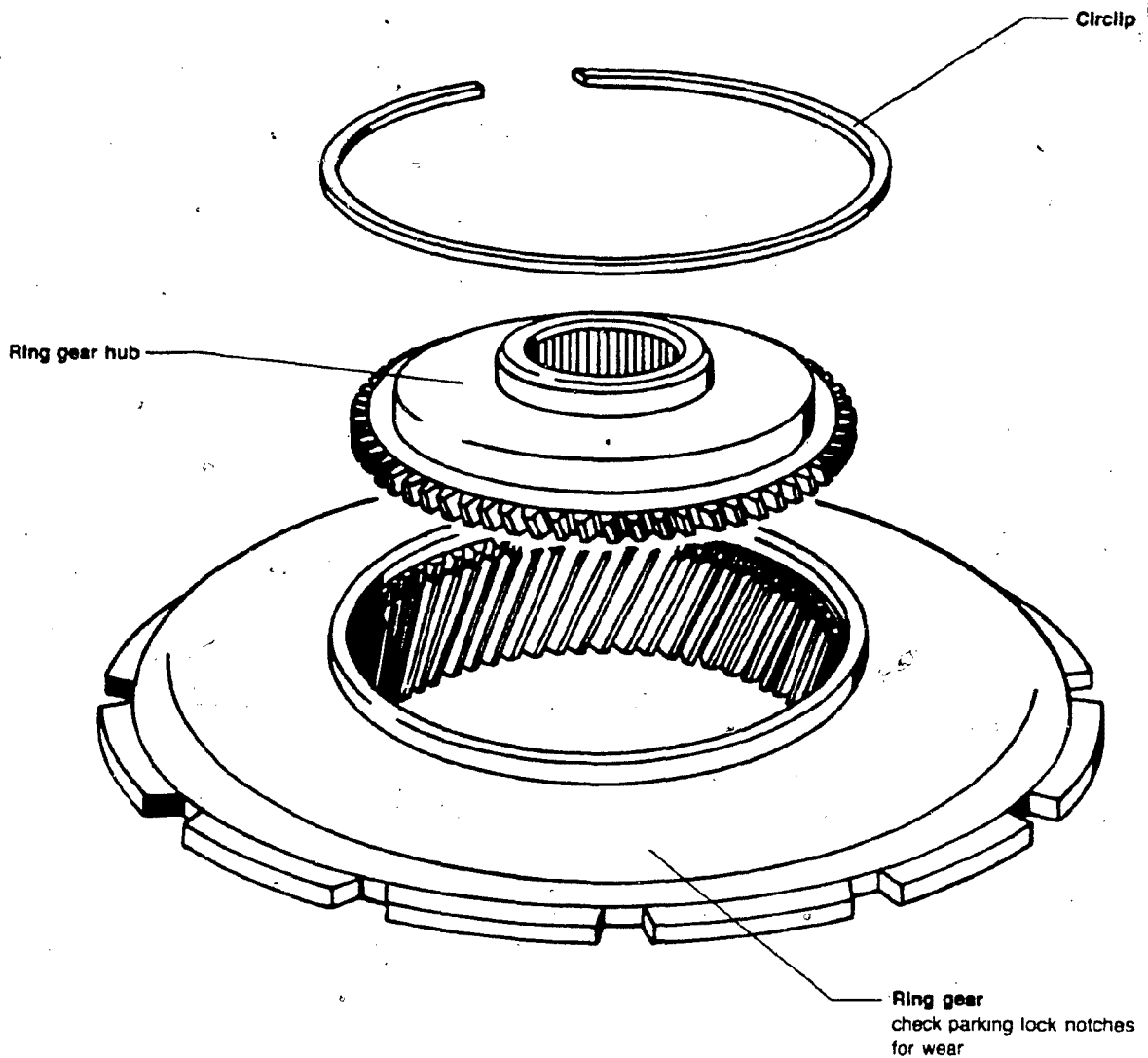

38-665

D-18

089

Reverse planetary ring gear

38.17

Automatic Transmission – Case, Gears, Shaft

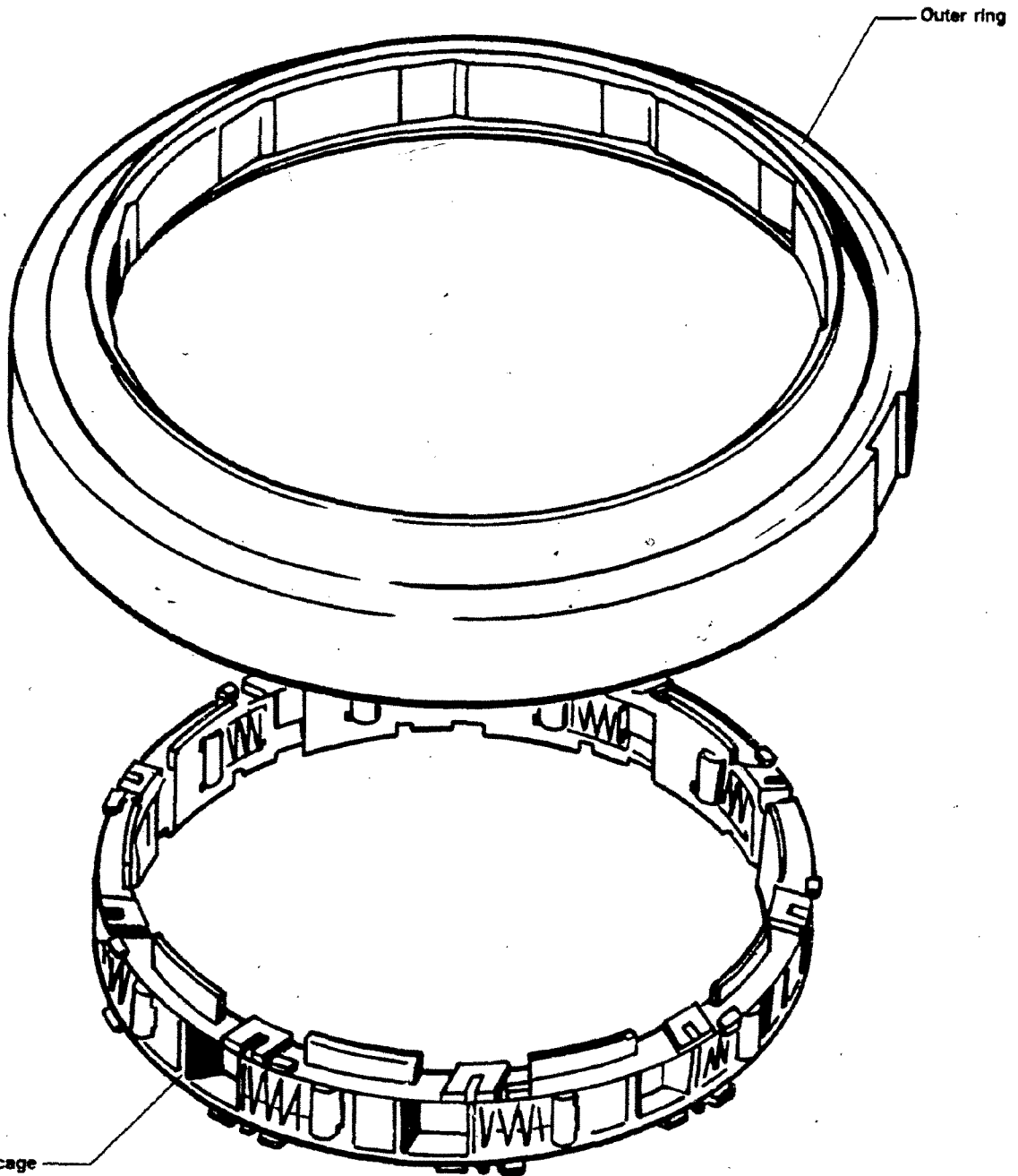

Outer ring

Plastic cage
with springs and rollers
segments. assembling Fig. 1
springs rollers, installing Fig. 2
cage, installation position Fig. 3
cage, securing Fig. 4

38-661

D-19

089

One way clutch

38.18

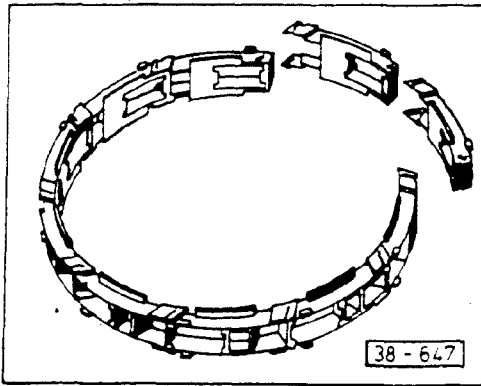

► Fig. 1 Segments, assembling

- assemble 10 segments together into a ring

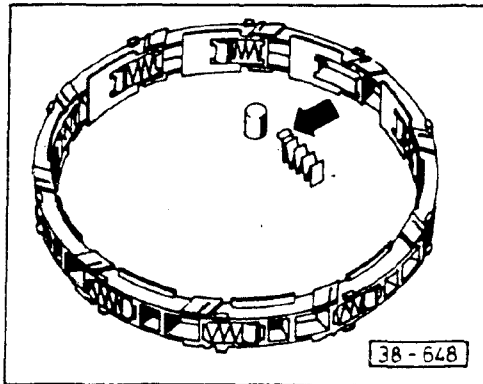
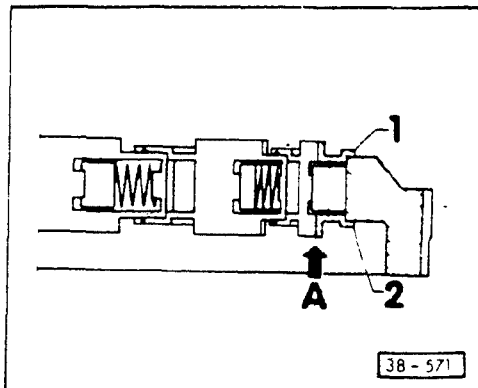

Fig. 2 Springs/rollers, installing

- install spring tab (arrow) toward roller



► Fig. 3 Cage, installation position

- insert cage into outer ring from below (direction of arrow A)
- small ledge 1 to top
- large ledge 2 to bottom

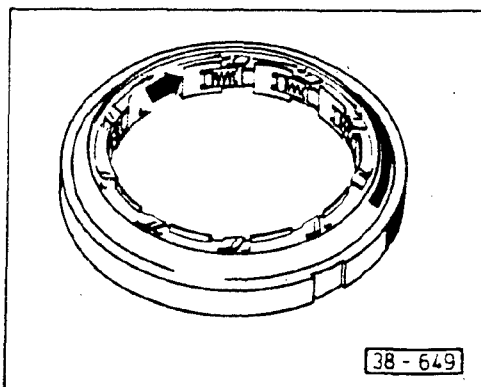

► Fig. 4 Cage, securing

- turn in direction of arrow

Automatic Transmission – Case, Gears, Shaft

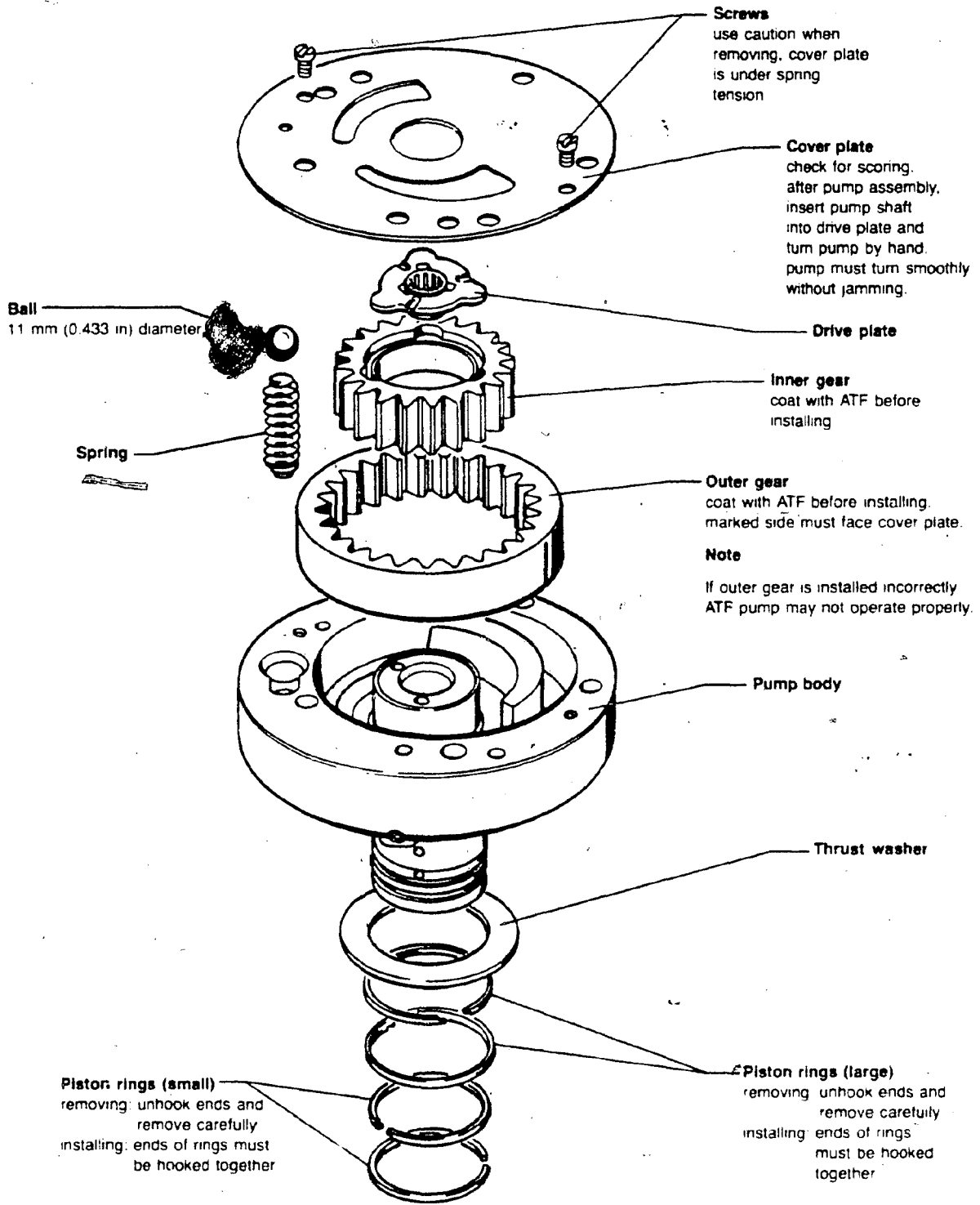

38-660

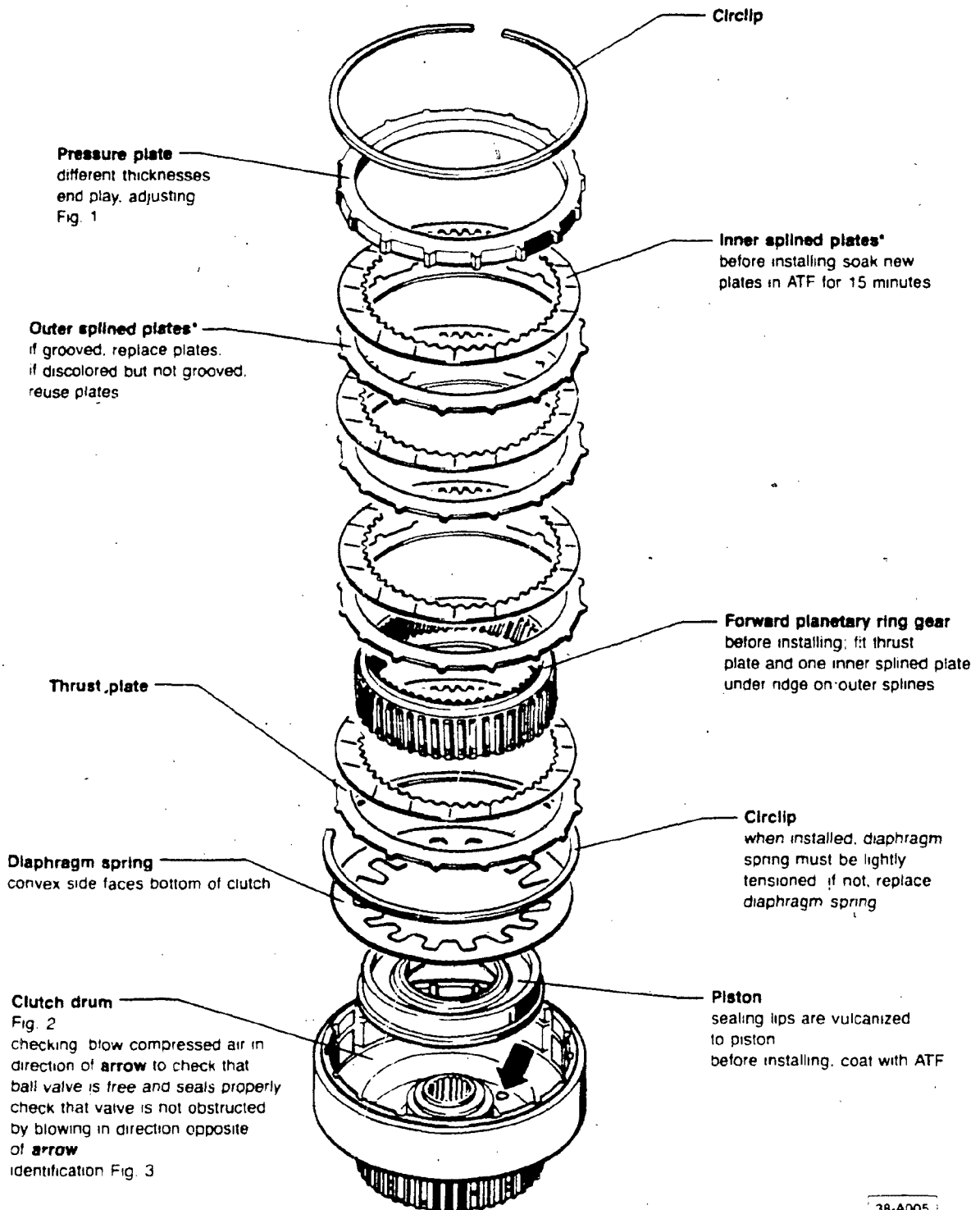

38-A005

*Number of plates, see table of
technical data Repair Group 37

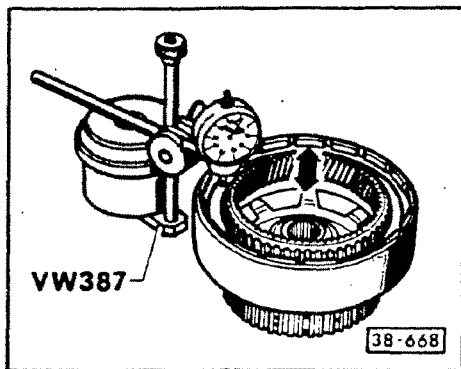

► Fig. 1 Forward clutch end play, adjusting

- check that end play (arrow) is between 0.5-0.9 mm (0.020-0.035 in.)

If NO,

- select new pressure plate using table

Thickness (mm)	Part no.
6.0	010 323 253 F
6.4	010 323 253 A
6.8	010 323 253 B
7.2	010 323 253 C
7.6	010 323 253 D

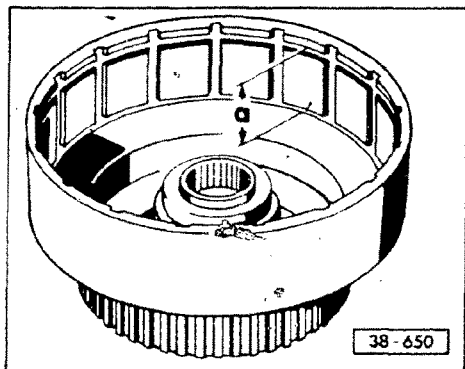

► Fig. 2 Forward clutch drum, assembling

- measure depth of groove for circlip
 - a = 29.8 mm (1.173 in.)

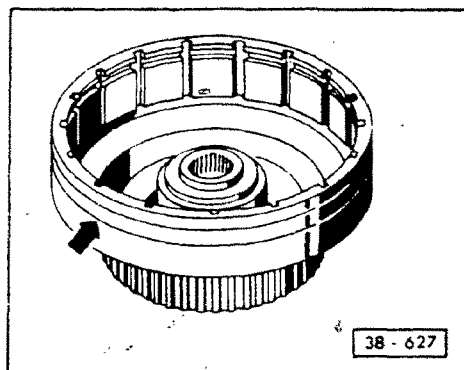

► Fig. 3 Forward clutch drum, identification

- 2 grooves (arrow)
- 2 groove clutch drum must be fitted with a 140 mm diameter direct/reverse clutch

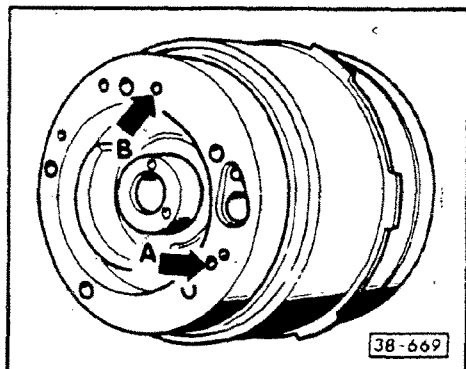

► Fig. 4 Forward clutch assembly, checking

- install forward clutch and direct/reverse clutch with needle bearing onto oil pump
- apply compressed air to port (arrow A)
 - piston must compress clutch plates
 - piston must return to original position when air pressure is released

CONTINUED IN THE
BEGINNING OF NEXT ROW

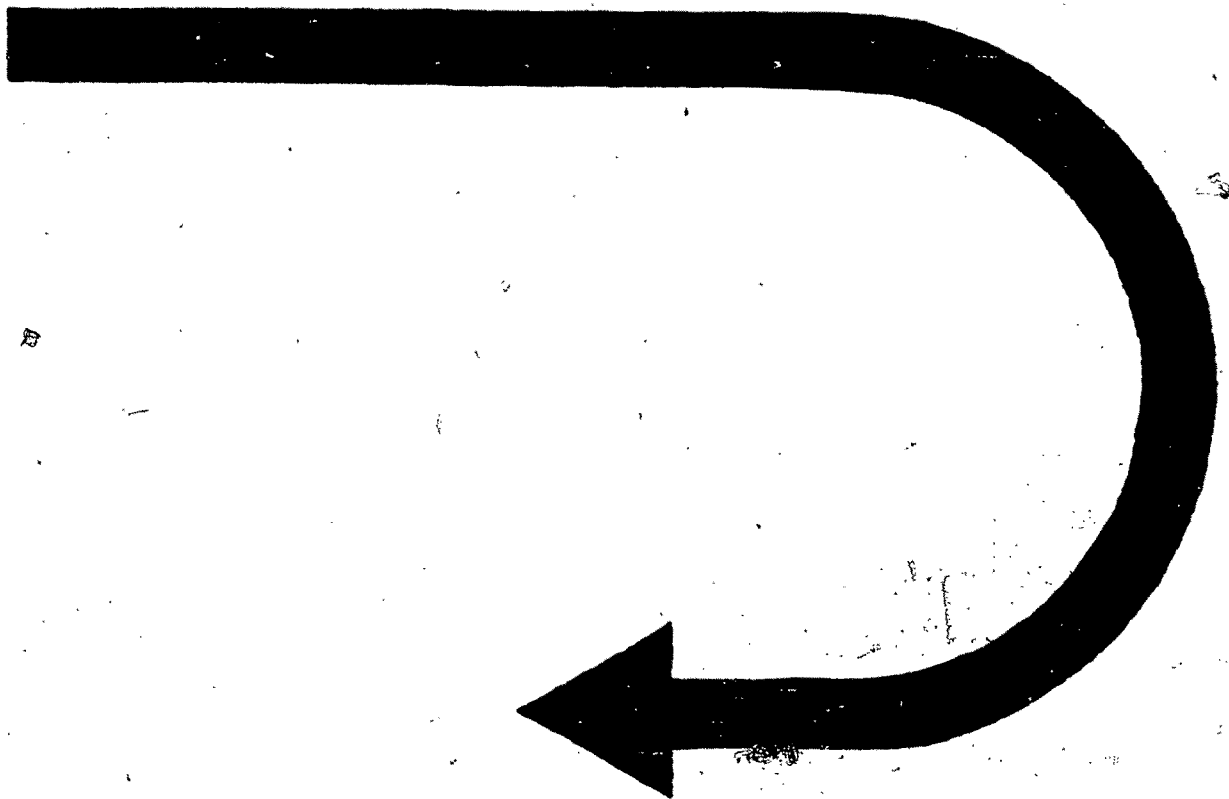

Automatic Transmission – Case, Gears, Shaft

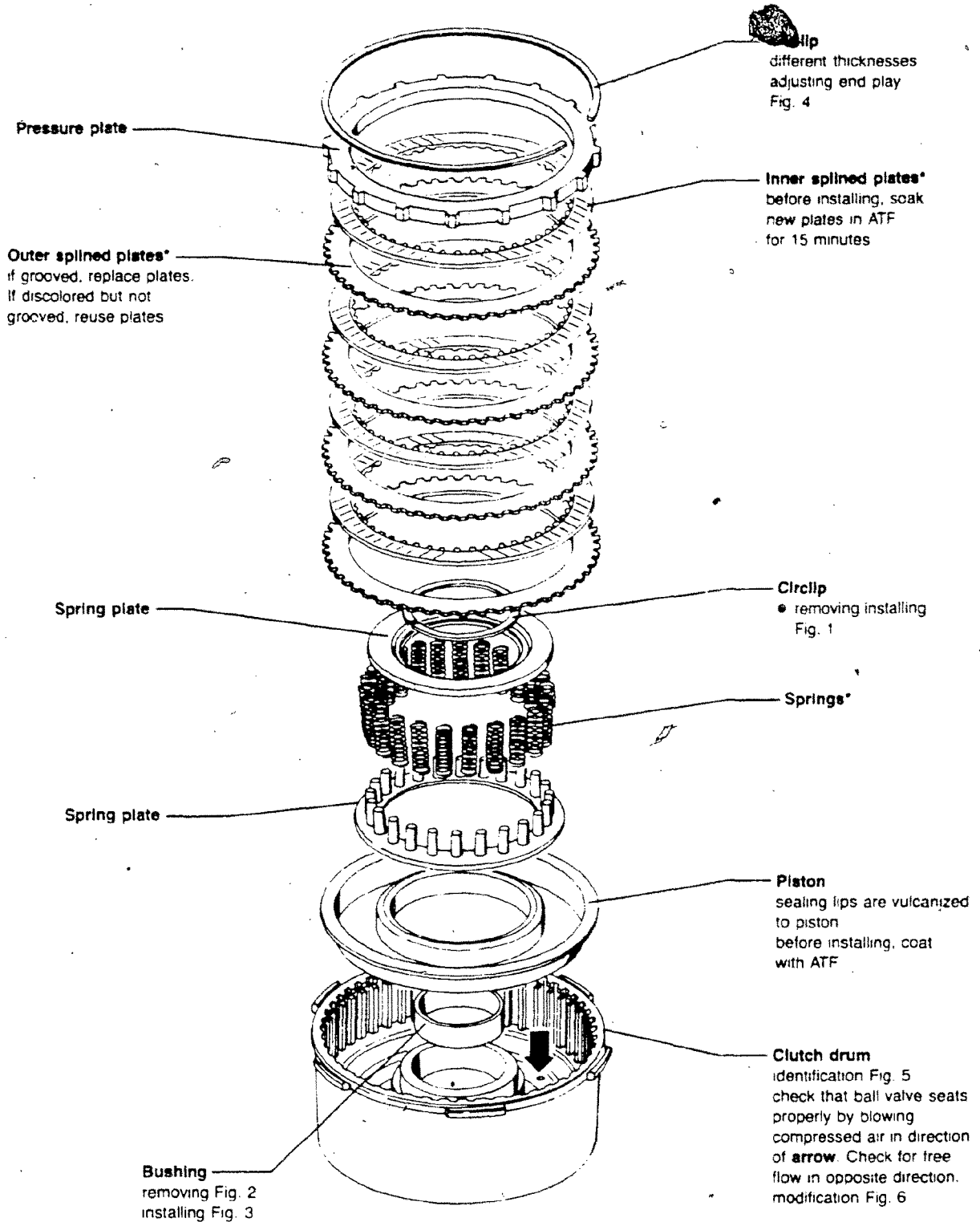

*Number of plates or springs, see table of technical data Repair Group 37

38-662

E-2

089

Direct/reverse clutch

38.23

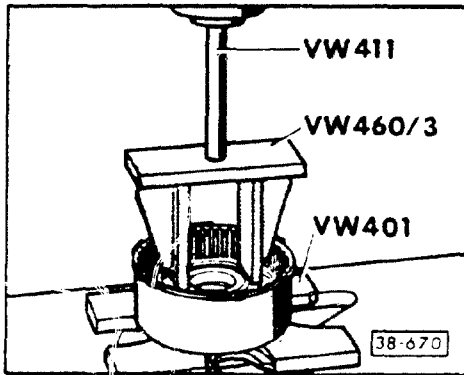

► Fig. 1 Circlip (small); removing/installing

- press down on spring plate

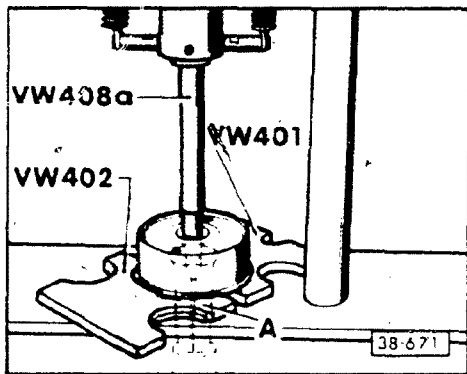

► Fig. 2 Clutch drum bushing, removing

- A = 37-46 mm puller US 1099 or Kukko 21/6

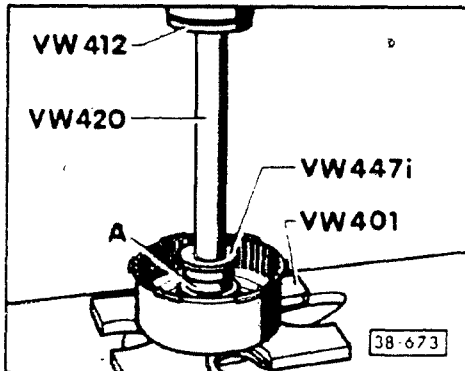

► Fig. 3 Clutch drum bushing, installing

- press bushing in flush with VW 433
- use old bushing A to press new bushing 1.7 mm (0.067 in.) below top edge

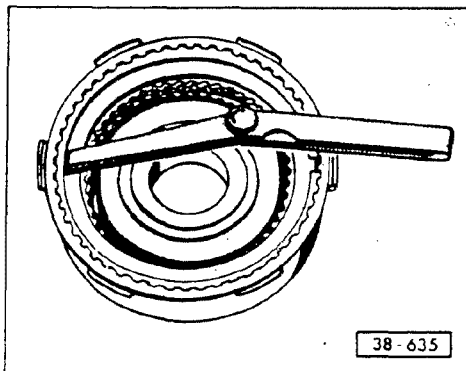

► Fig. 4 Direct reverse clutch end play, adjusting

- check that end play is 2.05-2.50 mm (0.081-0.098 in.)
- adjust if necessary by replacing circlip until correct clearance is obtained

CAUTION

Part numbers are for reference only. Always check with your Parts Department for latest information.

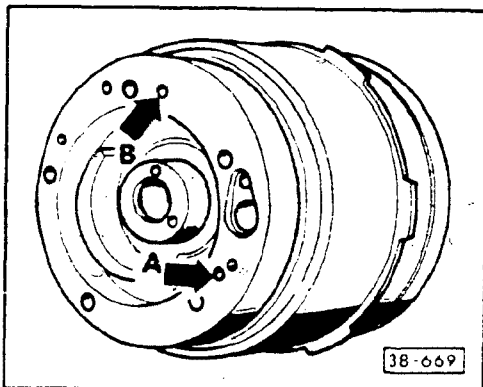
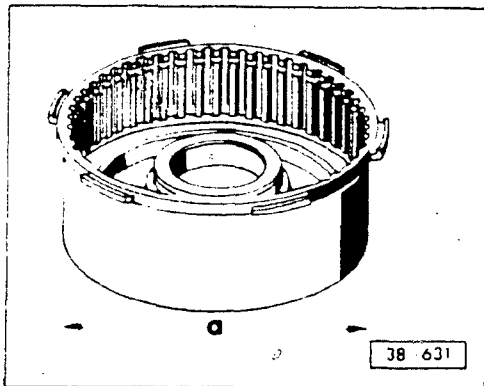
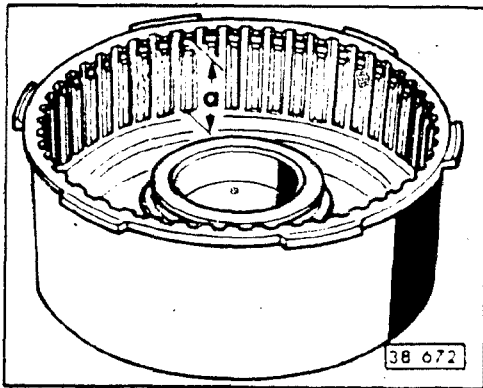

For 134 mm diameter clutch drum

Thickness (mm)	Part no.
1.5	010 323 157 E
1.7	010 323 157 F
2.0	010 323 157 G
2.3	010 323 157 H
2.5	010 323 157 J

For 140 mm diameter drum

Thickness (mm)	Part no.
1.5	087 323 157
1.7	087 323 157 A
2.0	087 323 157 B
2.3	087 323 157 C
2.5	087 323 157 D

► Fig. 5 Direct/reverse clutch drum, identification

- measure depth of groove for circlip
- $a \approx 31.25 \text{ mm (1.230 in.)}$
for 4 inner 4 outer plates

Note

Only install a clutch drum with 51 outer plate grooves.

► Fig. 6 Direct/reverse clutch drum, modification

- dimension a
clutch drum: 134 mm (5.37 in.) diameter
wider clutch drum: 140 mm (5.51 in.) diameter

Note

On the wider clutch drum the friction surfaces of the inner and outer plates and the pressure plate have been increased by 6 mm.

► Fig. 7 Direct/reverse clutch assembly, checking

- install forward clutch and direct/reverse clutch with needle bearing onto oil pump
- apply compressed air to port (arrow B)
 - piston must compress clutch plates
 - piston must return to original position when air pressure is released

**This page
intentionally
left blank**

Automatic Transmission – Case, Gears, Shaft

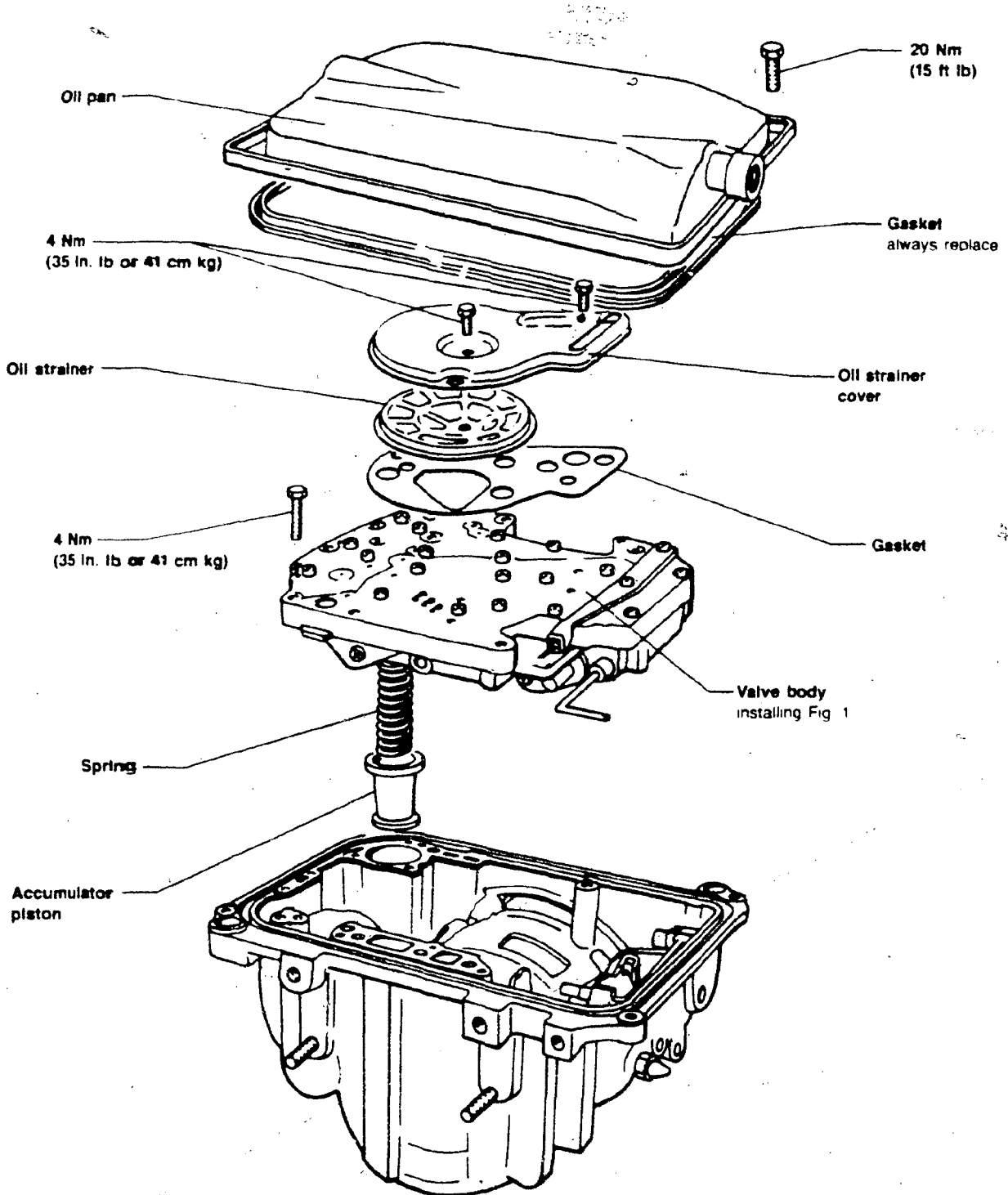

CAUTION

Do not run engine or tow vehicle when oil pan is off or with no oil in transmission.

Note

The valve body can be removed and installed with the transmission in the vehicle.

38-667

089

Valve body

38.26

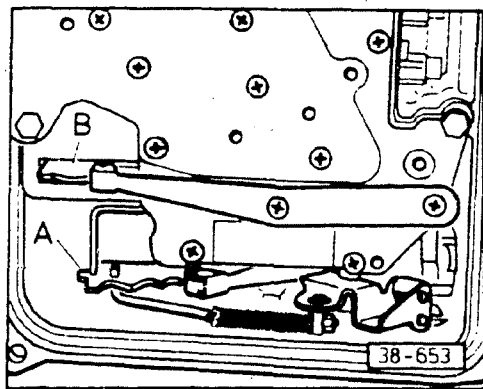

► Fig. 1 Valve body, installing

- fit valve body to transmission case
- connect manual valve **A** and kickdown valve **B**
- tighten all bolts diagonally to 4 Nm (35 in. lb or 41 cm kg)

Automatic Transmission – Case, Gears, Shaft

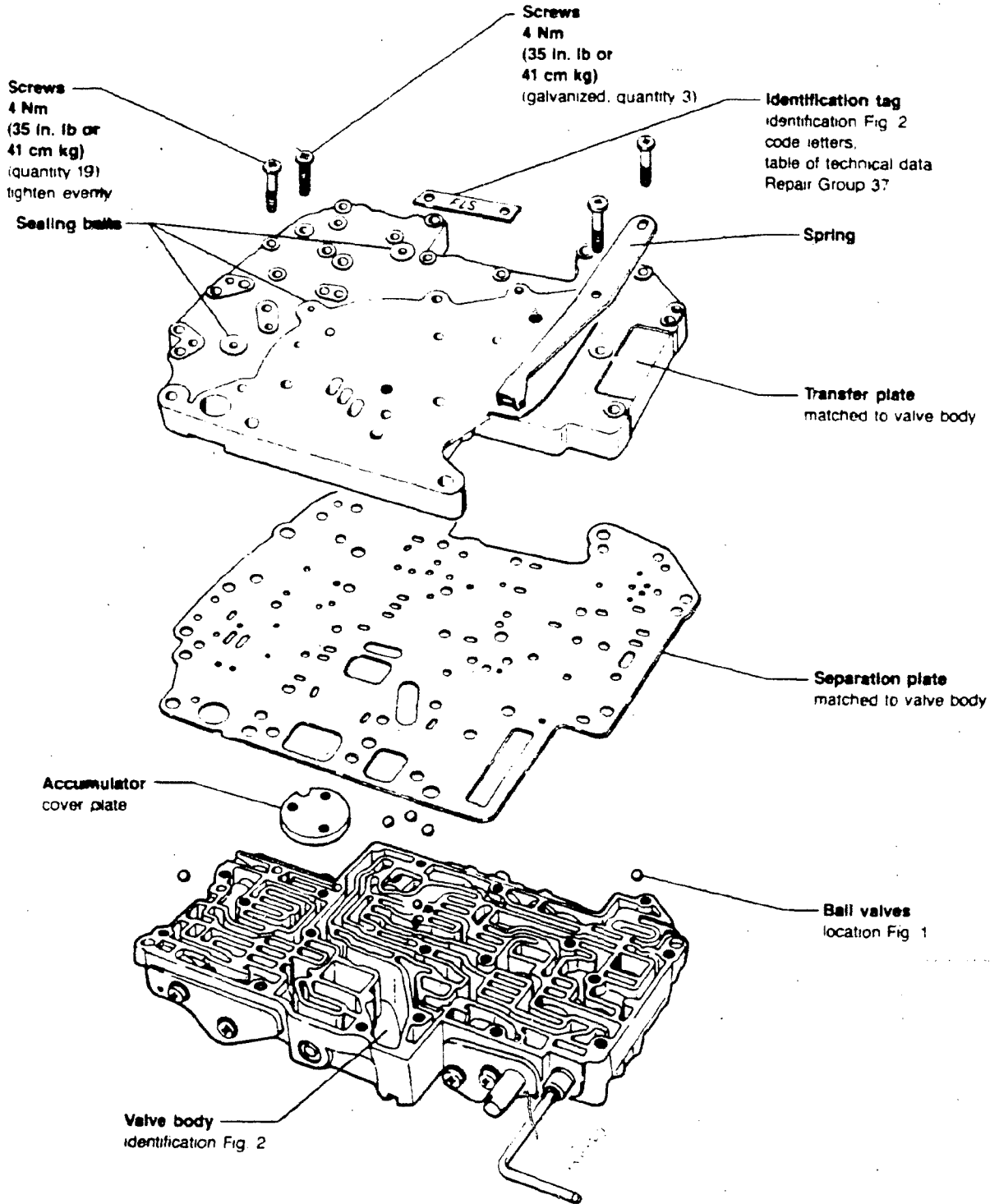

38-664

E-8

089

Valve body

38.28

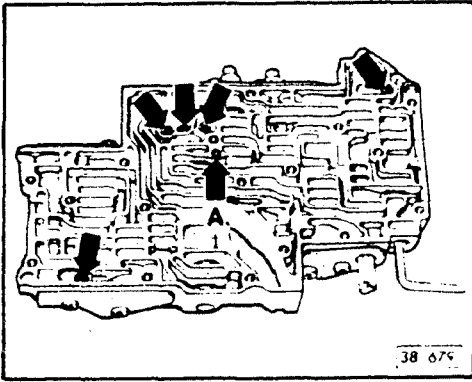

► Fig. 1 Ball valves, location

- (arrow A) 1 ball 3 mm diameter
- (arrows) 5 balls 6 mm diameter

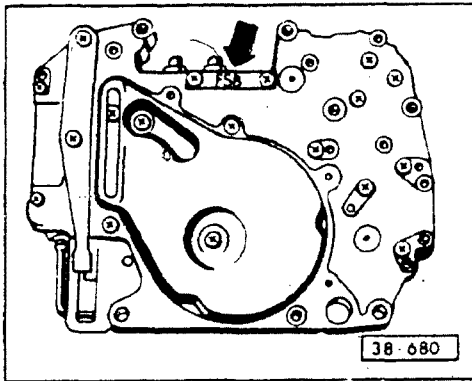

► Fig. 2 Valve body, identification

- code letters (arrow)
- see table of technical data Repair Group 37

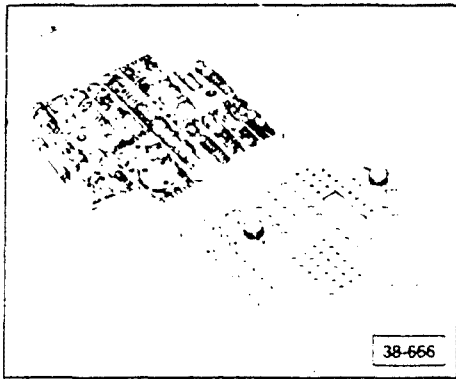

Valve body, disassembling/cleaning

Valve body should be disassembled for cleaning only when transmission failure was caused by burnt friction linings or excessively dirty ATF. If ATF is still fairly clean, place the complete valve body in cleaning solution and then dry it afterwards with compressed air.

Storage tray, tool number **2008/A**, is used to store all valves, springs and screws from valve body.

Tray outer shape corresponds to shape of valve body.

To be sure parts are reinstalled in their original location, they should be placed in storage tray.

Ball valves can be stored in space provided for bolts

- remove rear end plate, take out valves and springs one after another and place them in tray
- remove end plate from other side and repeat procedure
- place lid on tray
- immerse tray complete with parts in cleaning solution. Dry with compressed air. Do not use water, fluffy rags or cloths when cleaning parts

Valve body, assembling

Lubricate all parts with ATF when assembling and check for free movement. Valves should slide under their own weight.

Valves which are slightly scored may be reused. This will not affect operation of transmission.

All parts must be completely clean.

Valves and springs must be put back into same holes from which they were removed

- insert springs and valves into one side in locations shown in exploded view and then install end plate before proceeding with other side

**This page
intentionally
left blank**

Automatic Transmission – Case, Gears, Shaft

Spring measurements
see spring table page 38 32

Note

Circled numbers correspond
to those in spring table

CAUTION
Several valve springs have the same
dimensions. However do not interchange
because they have different tolerances.
• storage tray for valve cleaning page
38 30

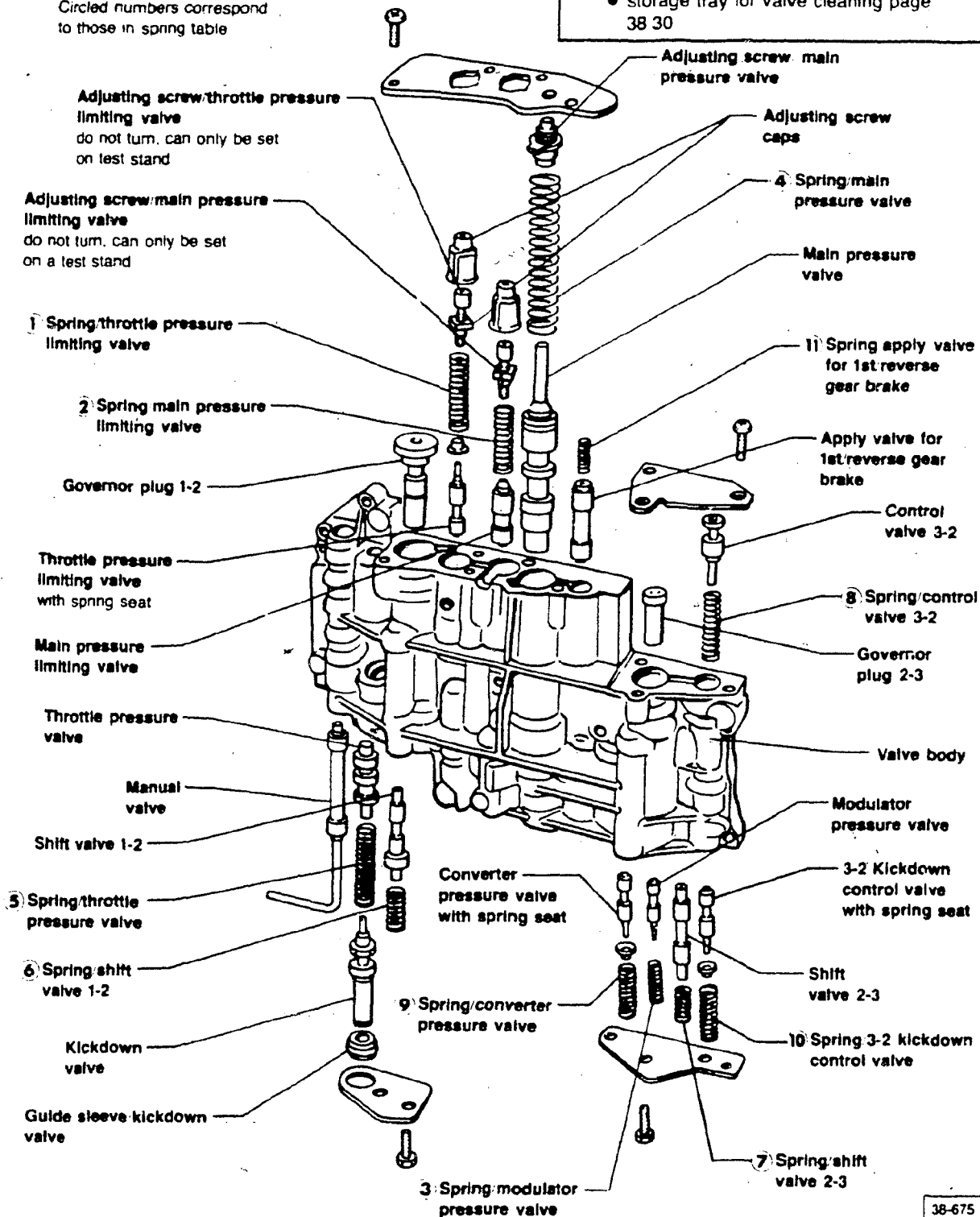

38-675

Spring table

This table allows identification of springs by their dimensions. Coil diameter and free length can vary between new and used springs (due to settling) so when identifying springs check the spring wire thickness and the number of coils first. Then if necessary check the spring inner diameter and free length.

CAUTION

Valve springs of similar dimensions must not be interchanged due to different tolerances.

Description	Coils	Wire thickness mm (in.)	Free length ¹ mm (in.)	Spring inner diameter ² mm (in.)
① Spring/throttle pressure limiting valve	14.5	1.1 (0.043)	37.9 (1.492)	7.7 (0.303)
② Spring/main pressure limiting valve	12.5	1.2 (0.047)	27.5 (1.083)	7.6 (0.299)
③ Spring/modulator pressure valve	11.5	0.8 (0.031)	28.6 (1.126)	7.75 (0.305)
④ Spring/main pressure valve	16.5	1.4 (0.055)	69.2 (2.724)	11.9 (0.469)
⑤ Spring/throttle pressure valve	16.5	1.1 (0.043)	44.0 (1.732)	7.75 (0.305)
⑥ Spring/shift valve 1-2	8.5	0.9 (0.035)	28.8 (1.134)	8.1 (0.319)
⑦ Spring/shift valve 2-3	8.5	0.8 (0.031)	17.4 (0.685)	6.95 (0.274)
⑧ Spring/control valve 3-2	12.5	1.0 (0.039)	32.4 (1.276)	7.7 (0.303)
⑨ Spring/converter pressure valve	8.5	1.25 (0.049)	22.2 (0.874)	7.7 (0.303)
⑩ Spring/3-2 Kickdown control valve	11.5	0.9 (0.035)	28.4 (1.118)	8.1 (0.319)
⑪ Spring/apply valve for 1st reverse gear brake	8.5	0.5 (0.020)	26.6 (1.047)	6.5 (0.256)

¹Free length can vary due to tolerances and settling

²Inner coil diameter tolerance is ± 0.3 mm (0.012 in.)

Automatic Transmission – Case, Gears, Shaft

Note

Lubricate all sealing rings with ATF before installing.

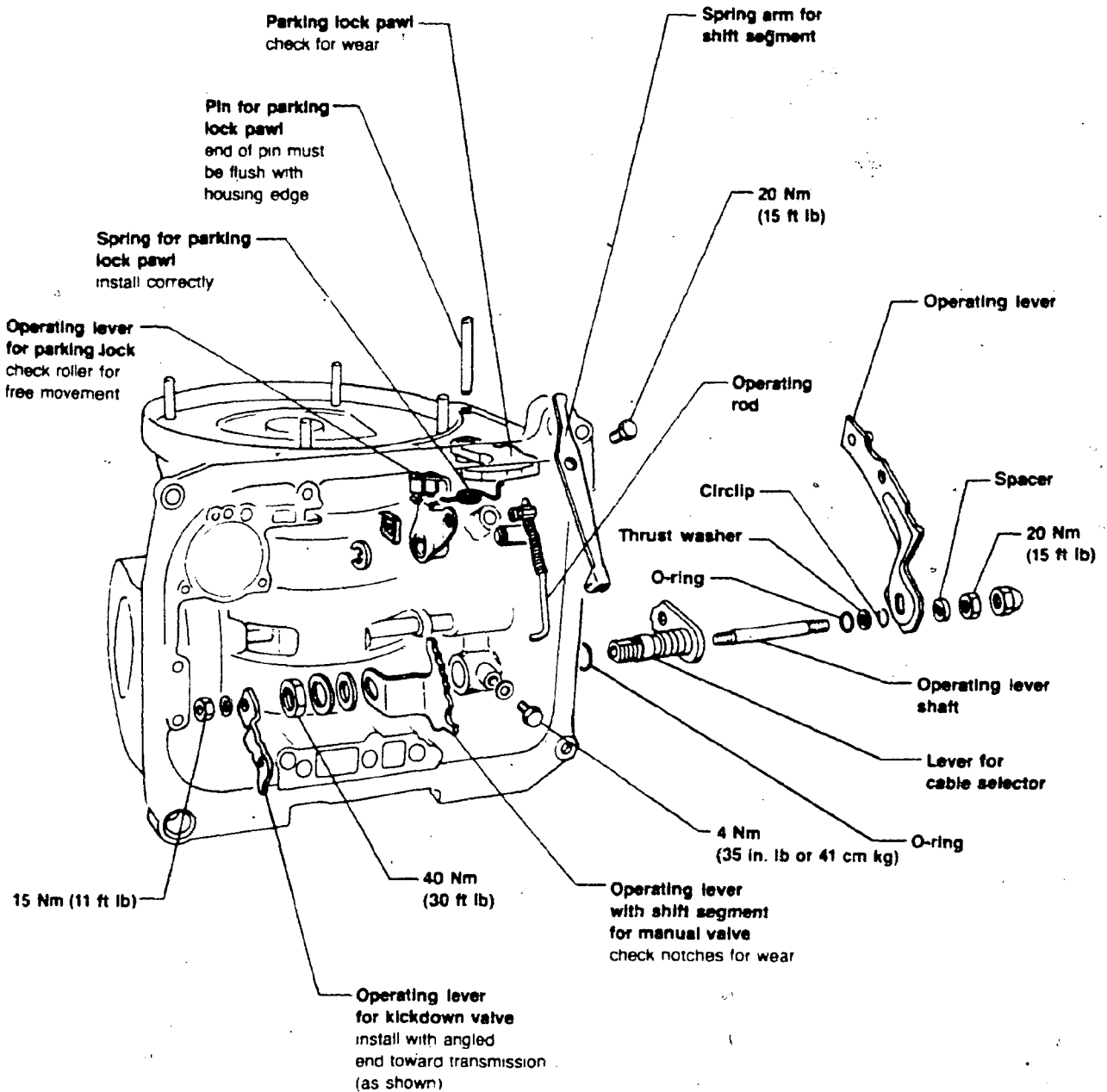

38-676

E-14

089

Parking lock

38.33

CONTINUED IN THE
BEGINNING OF NEXT ROW

