

Index

Two-wheel drive

ABS rotor

- pressing in 42.5

Bonded rubber bushings

- replacing 42.3

Grease cap

- removing 42.5

Rear Axle

- assembly 42.2
- installing 42.7
- removing 42.6

Shock absorber

- assembly 42.8
- noise 42.9

Spring plate

- installing 42.9

Suspension strut

- assembly 42.8
- removing 42.7

Wheel hub/axle

- assembly 42.4
- bearing 42.5
- bearing adjusting 42.2

Rear Wheel Suspension – Shafts & Axle

CAUTION

DO NOT attempt to weld or straighten the axle beam.

CAUTION

Always replace self-locking nuts used to secure rear suspension components when repairing.

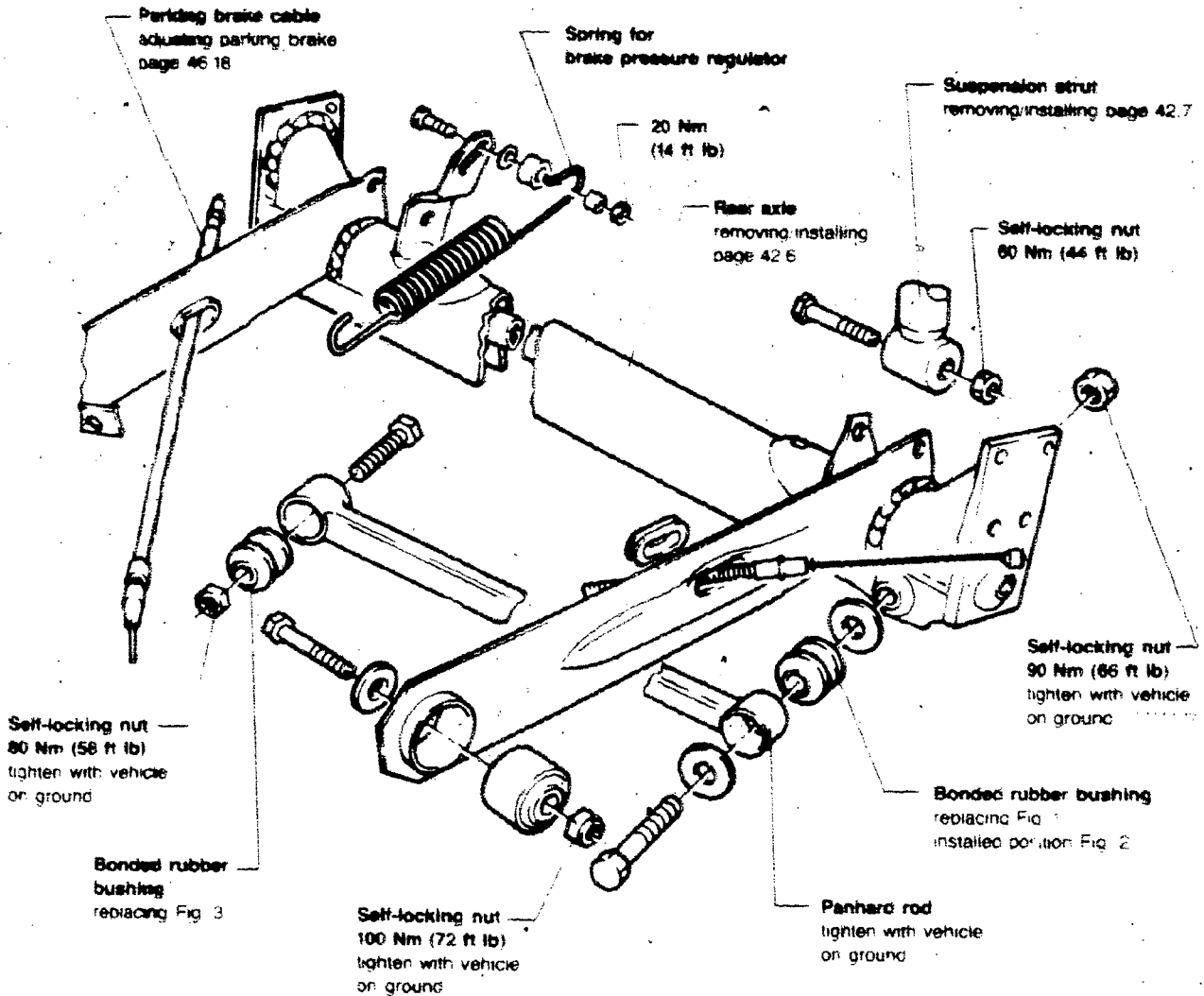

42-715

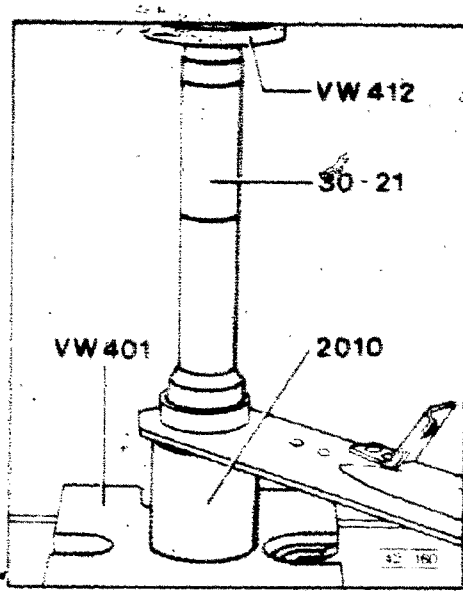

► Fig. 1 Bonded rubber bushing, replacing
■ press bushing in flush

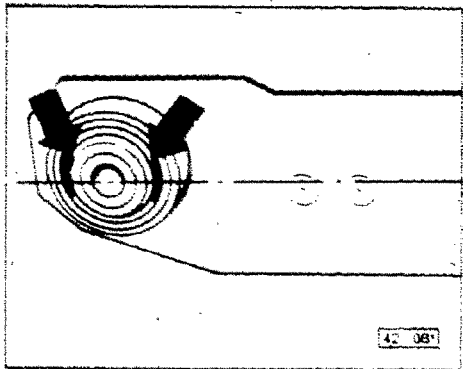

► Fig. 2 Installed position of rubber bushing

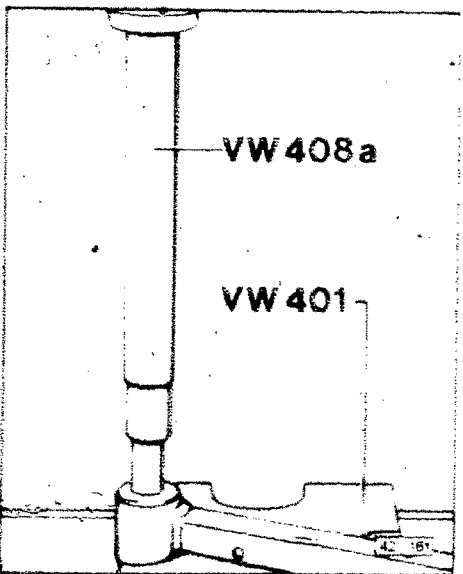

► Fig. 3 Bonded rubber bushing, replacing

Rear Wheel Suspension – Shafts & Axle

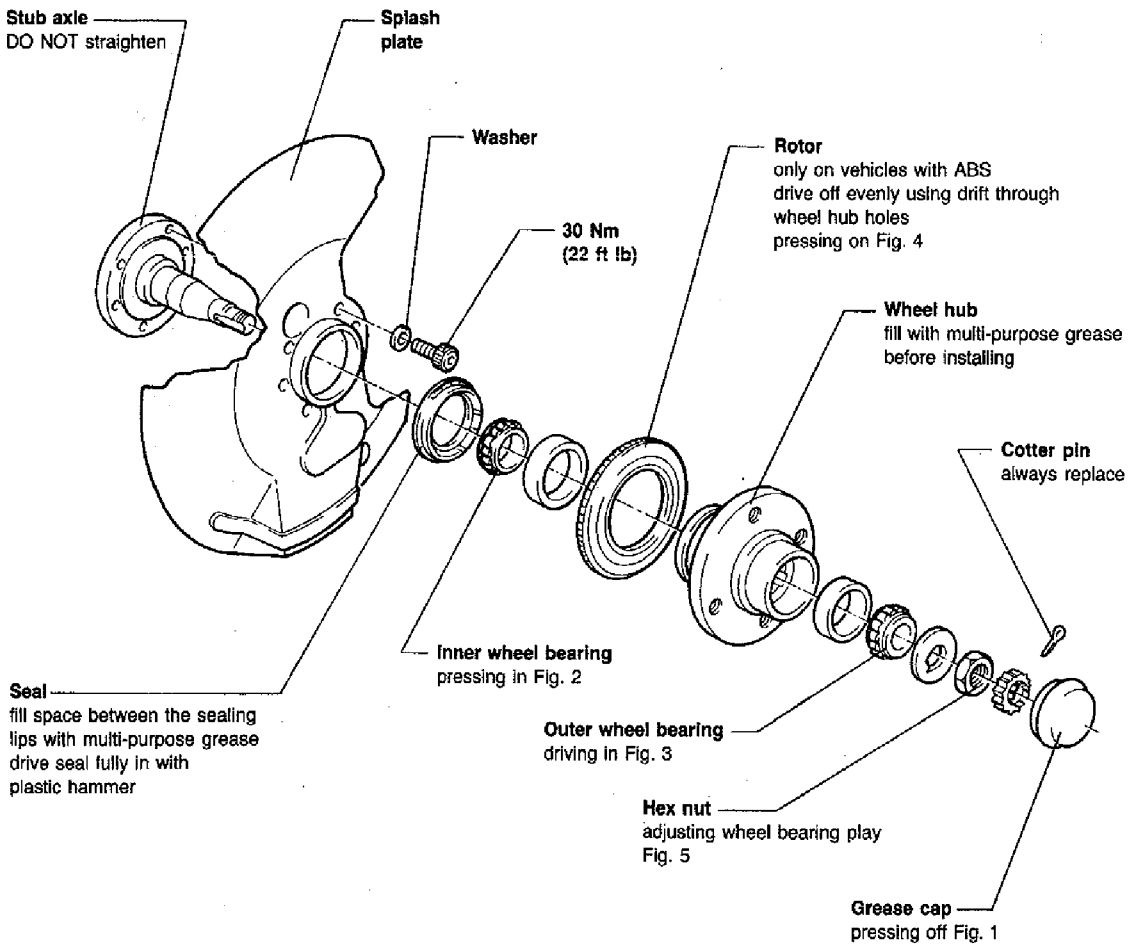

42-596

Rear Wheel Suspension – Shafts & Axle

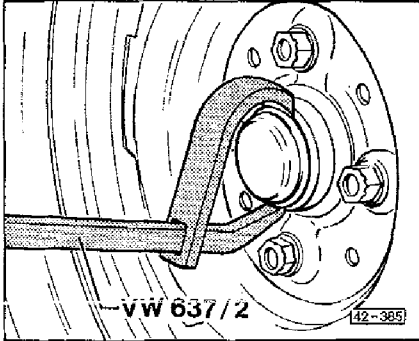

► Fig. 1 Grease cap, pressing off

- move grease cap slightly off wheel hub by lightly tapping claw of special tool with a hammer

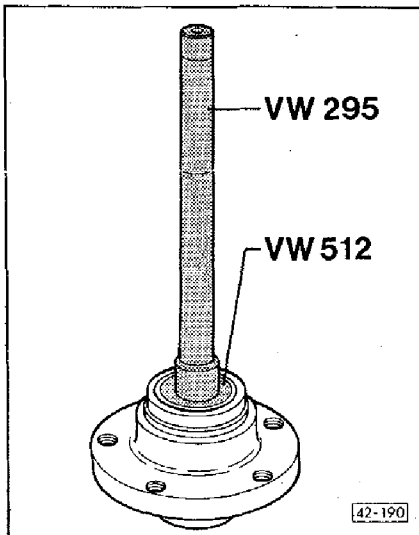

► Fig. 2 Inner wheel bearing outer race, pressing in

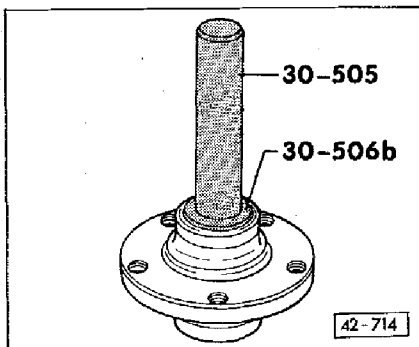

► Fig. 3 Outer wheel bearing outer race, driving in

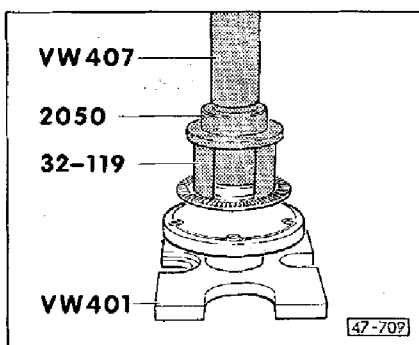

► Fig. 4 Rotor, pressing in (vehicles with ABS)

Rear Wheel Suspension – Shafts & Axle

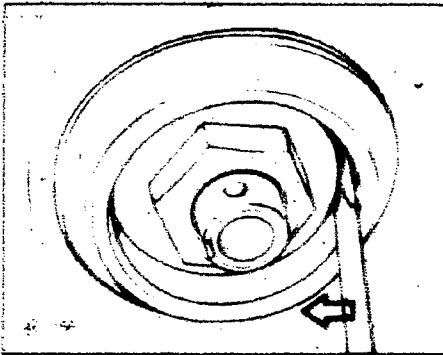

► Fig. 5 Wheel bearing play, adjusting

Note

The wheel bearing is correctly adjusted when the thrust washer can just be moved with a screwdriver (arrow), using finger pressure (not by turning or prying).

Rear axle, removing/installing

Work sequence

Removing

- remove rear wheels
- remove compensator bar (top arrow)
- remove handbrake cable from clips at support bracket (lower arrows)

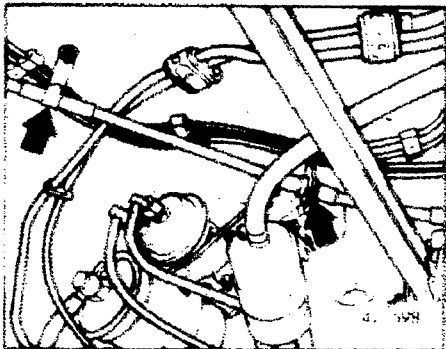
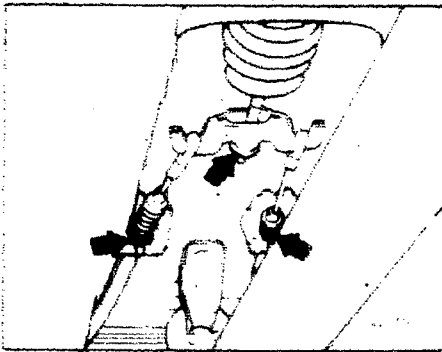

- pry guide sleeves for handbrake cable out of support brackets (arrows)

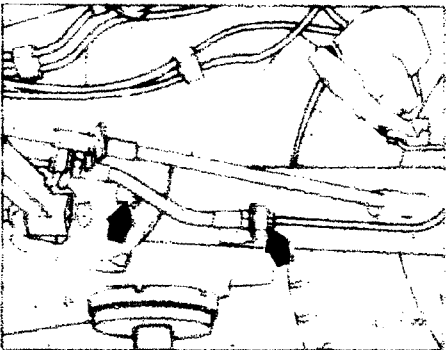

- disconnect brake lines from brake hoses (right arrow)
- remove nuts from trailing link mounting bolts (left arrow). DO NOT take bolts out
- disconnect brake pressure regulator spring at rear axle

Rear Wheel Suspension – Shafts & Axle

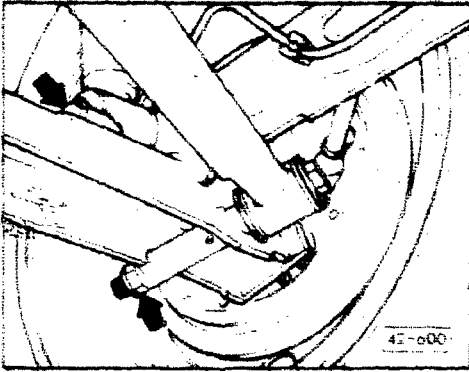

- remove bolt securing Panhard rod (lower arrow)
- remove bolts for suspension strut mounting at bottom (upper arrow)
- remove trailing link mounting bolts (two mechanics required)
- remove rear axle

Installing

Proceed in reverse order of removing and note the following:

- bleed brake system, page 47 14
- adjust parking brake, page 46 18

Suspension strut, removing

Work sequence

Note

The suspension struts may only be removed one side at a time. Otherwise the brake hoses will be stretched and damaged.

(Vehicle standing on wheels)

- remove luggage compartment trim
- remove cover plate
- unscrew nut from piston rod (hold rod up with special tool 3079)

- raise vehicle
- remove lower bolt (arrow)

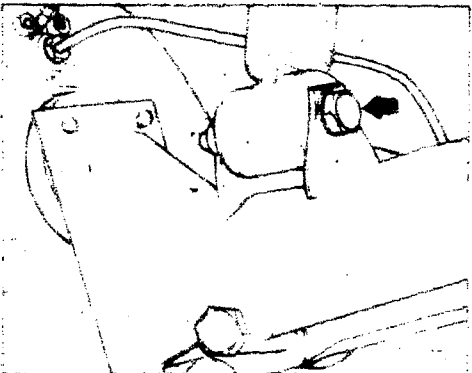
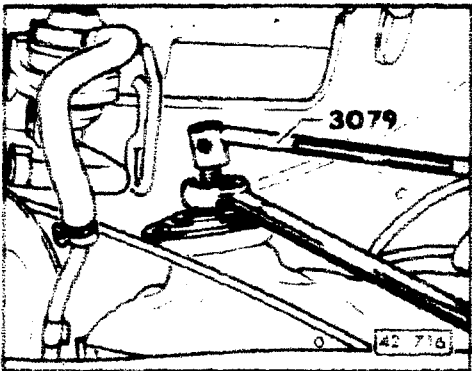

Rear Wheel Suspension – Shafts & Axle

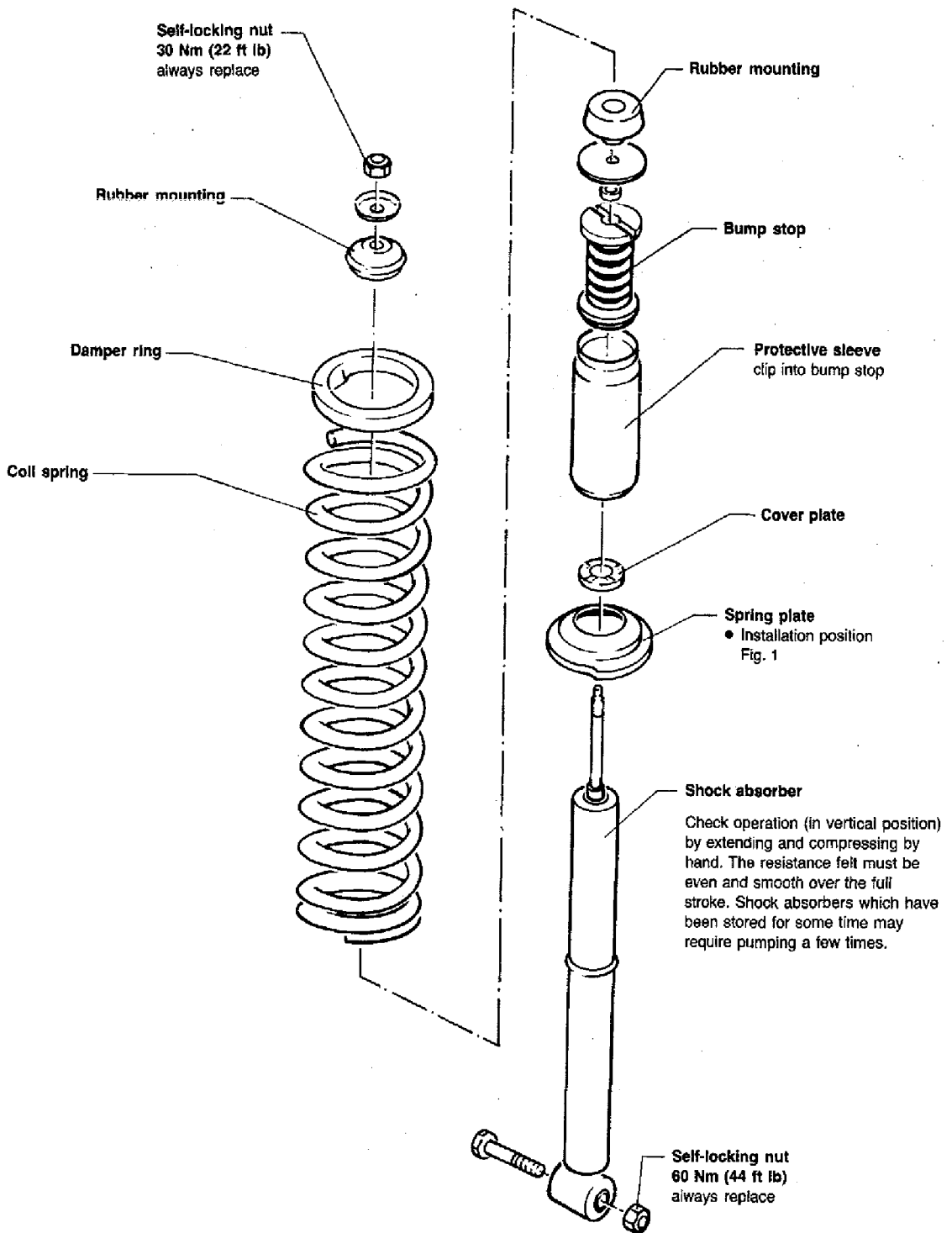

42-594

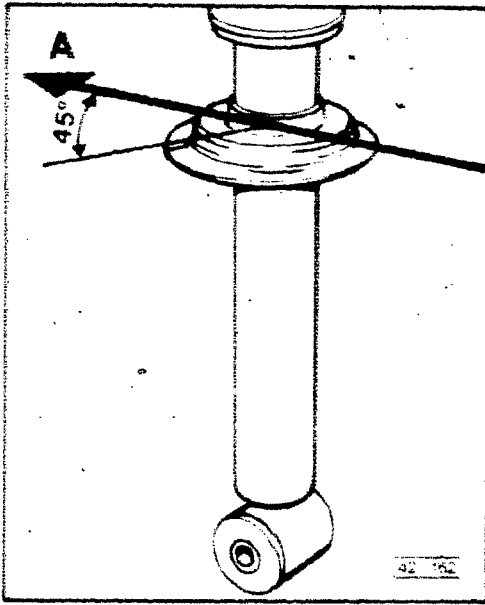

► Fig. 1 Installation position of spring plate

The notch on the spring plate points 45° to the left, as seen in direction of vehicle travel (A).



Rear shock absorber noise

Use the following procedure to eliminate noise (squeaking, creaking) from the rear suspension when driving over bumps or during braking:

- raise rear of vehicle
- remove lower shock absorber bolt
- separate shock absorber from axle support bracket

CAUTION

Do not allow rear axle to hang from body mounts only, as brake lines could be damaged

- apply silicone grease to both sides of lower shock absorber bushings (arrows)
- install shock absorber to lower bracket using new lock nut. Do not tighten nut
- repeat procedure on opposite side of vehicle
- lower rear of vehicle to ground
- torque lower rear shock absorber nuts to 90 Nm (66 ft lb)